

TRANSLATION LINKS

1. type into your browser ... **english+italian+glossary+nautical terms**
2. utilise the translation dictionary 'Nautical Terms & Expressions' from Euromodel website

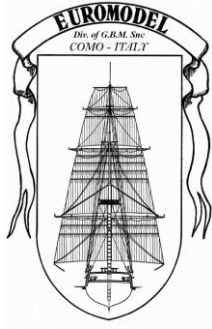

Resources for the Lyde

November 2020

This resource information file was based on the original text supplied by Euromodel and then expanded in detail as the actual ship was constructed by the author, Peter Coward.

Whilst relating to the basic build of this ship, there is information in Chapter 4 that is for the advanced builder who may wish to pursue more detailed work.

Neither the author nor Euromodel have any commercial interest in this information and it is published on the Euromodel web site in good faith for other persons who may wish to build this ship. Euromodel does not accept any responsibility for the contents that follow.

Lyde



Traditional schooners were gaff-rigged (four-sided sails generally supported by booms) but often had at least one square top sail. The Lyde had a total of eight sails.

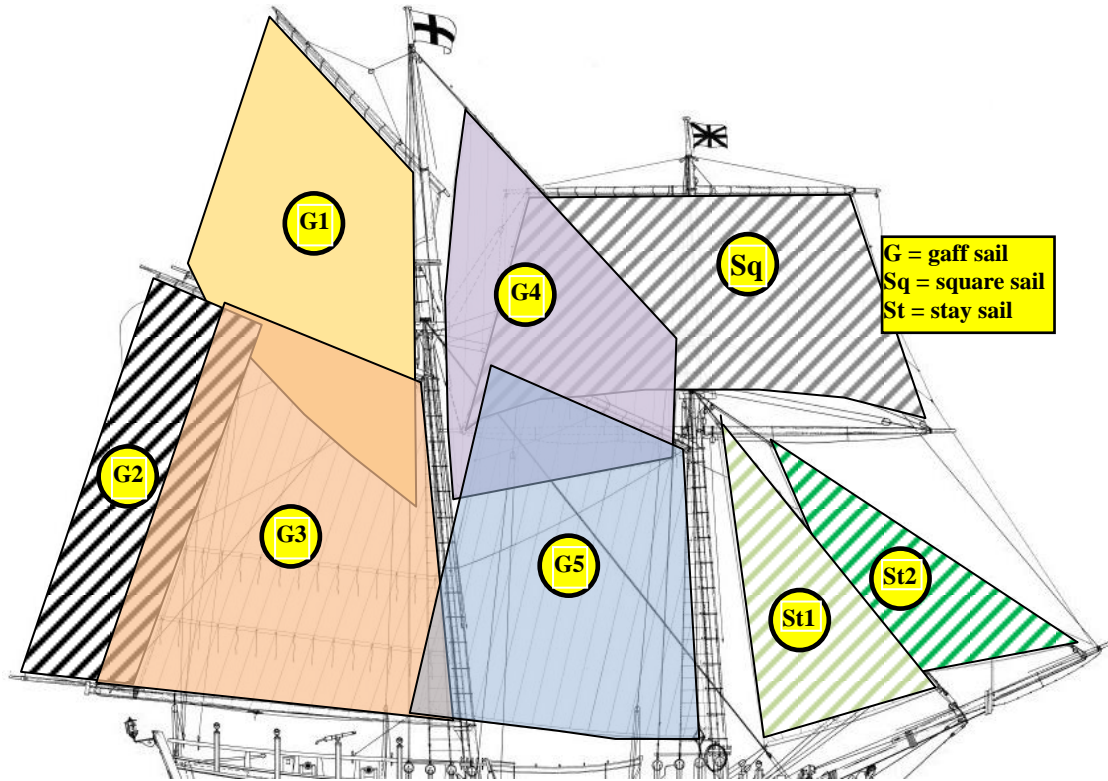

[To navigate through the contents – use ‘control + click’]

Contents

Euromodel Preview.....	6
Chapter 1: INTRODUCTION.....	7
Historical Notes	7
Construction Philosophy.....	8
Kit Building versus ‘Scratch’ Building.....	8
How <i>Did</i> I Build This Ship?	9
Chapter 2: TRANSLATION (from Italian to English)	10
Chapter 3: THE KIT	15
Drawings	15
Metal Decorations	15
Component List.....	16
Chapter 4: MORE ADVANCED IDEAS	18
Measurements	18
Treenail (or trenail, trennel or trunnel)	20
Rigging Tool	21
Plank Bending.....	22

Illustrations

[The figures below are not hyperlinked]

Figure 1: Working Towards a Scratch Model.....	8
Figure 2: A Difference !.....	15
Figure 3: Metal Identification	15

Euromodel Preview

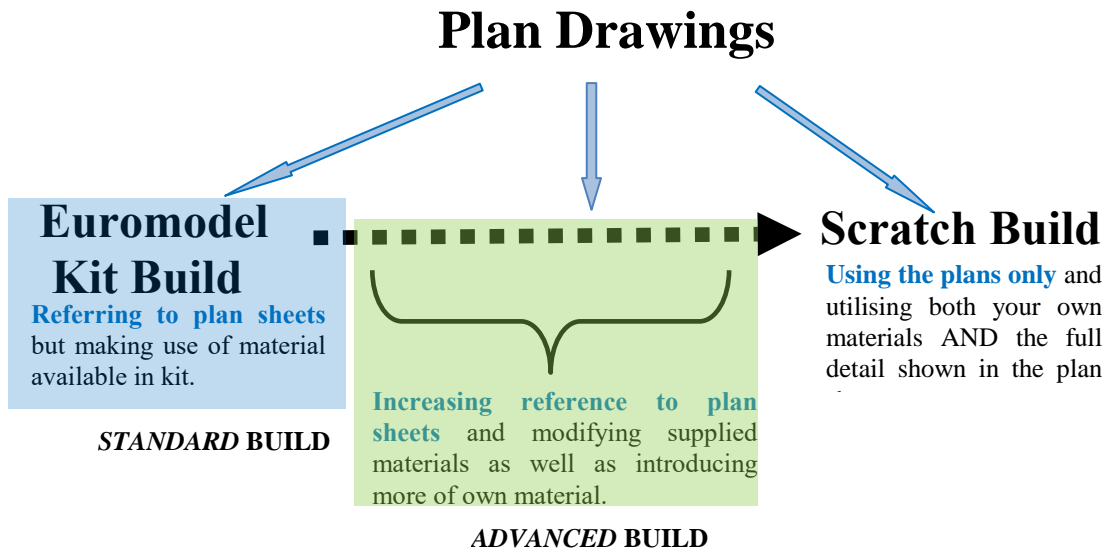

Euromodel kits are based on sets of drawings by a naval architect and contain a comprehensive amount of detail that would be a challenge to the most serious ship modeler. This is in contrast to most other kits that whilst they also contain excellent plans, the intention there is to achieve a build similar to the plans provided. Euromodel offers plans that can be interpreted at various levels of complexity. If the builder has limited experience in the craft of shipbuilding, then the plans can be read at a simplistic level.

Whilst *all* plan drawings are important to the construction of the Lyde, the builder is well advised to focus on three – Plan Sheets 1, 2 and 4.

When building individual components, *reference* and *comparisons* should be made between Plan Sheet 8 and the other drawings.

It could well be argued that *the outcome is somewhere on the continuum between a standard model construction and a scratch model*. How far you wish to extend this continuum is up to you and your build of this ship will be determined by the degree of complexity you choose (refer to the diagram above).

The kit material will go a long way towards achieving a good model but be aware that the purchase of some extra material might be necessary depending on how far you wish to go in emulating the plans. There will be little left over from the kit contents, but during the construction you should experience a compelling drive to create something better than the basic model. Euromodel is aware of this challenge and so provides just the basic needs and leaves it up to the modeler to determine how far he will extend his skills.

In summary ... my comments are not prescriptive and if the detail is sometimes a little too precise, please do not let this deter you. It will be up to you to take as much information as you wish and the rest to 'throw overboard'. It is your model, your creation, your handiwork.

Chapter 1: INTRODUCTION

Historical Notes

The Lyde was built in an English shipyard near Plymouth around 1787 as an armed cargo boat. It was used as a transport for war materials to support the English ships at the siege of Genova during the Napoleonic Wars.



Maximum Length 870 mm.
Maximum Width 410 mm.

Hull Length 570 mm.
Hull Width 160 mm.

Maximum Height 740 mm.
Scale 1:70

EUROMODEL
Euromodel Division of the GBM Snc di Mazza Massimo & C.
Via Aldo Galli, 11
22100 COMO (CO)
ITALY

e-mail : euro@euromodel-ship.com
home page <http://www.euromodel-ship.com>

Any submitted photos & comments will become the property of Euromodel Division of the GBM Snc di Mazza Massimo & C

Construction Philosophy

Euromodel have tried to simulate all the designs of the ‘Lyde’ in every possible way, with attention to detail in order to appeal to the advanced model builder to construct this model. The designs allow you to construct the vessel using both pre-cut materials ready to use, and materials that require preparation.

Kit Building versus ‘Scratch’ Building

There may well be some confusion in looking at the plans since there is considerable detail intended for the ‘scratch’ builder but which is not provided for in the kit. This kit has a comprehensive array of items to utilise in building this ship. In many cases, these items may not display exactly the same dimensions as the plan sheets but nevertheless will enable the construction of a fine ship. The kit builder will use what is provided but the scratch builder will utilise the plans more fully and decide to spend far more time building particular items.

A classic example of a step above the kit approach is illustrated in Fig. 1 where another deck is constructed (shaded pale green). The kit only provides three decks (Forecastle, Main and Quarter Decks) in laser-cut shapes and yet a quick perusal of Plan Sheet 1 clearly shows the existence of another deck, the Upper Quarter Deck. This illustrates the fact that the plans are really for a scratch build that can be modified to produce a kit model. This extra deck can easily be formed by the builder and yet also can be left out ! Your choice. Other instances will appear which at first glance will suggest some component is missing from the kit but the reality is it will suggest that *something extra could be provided*.

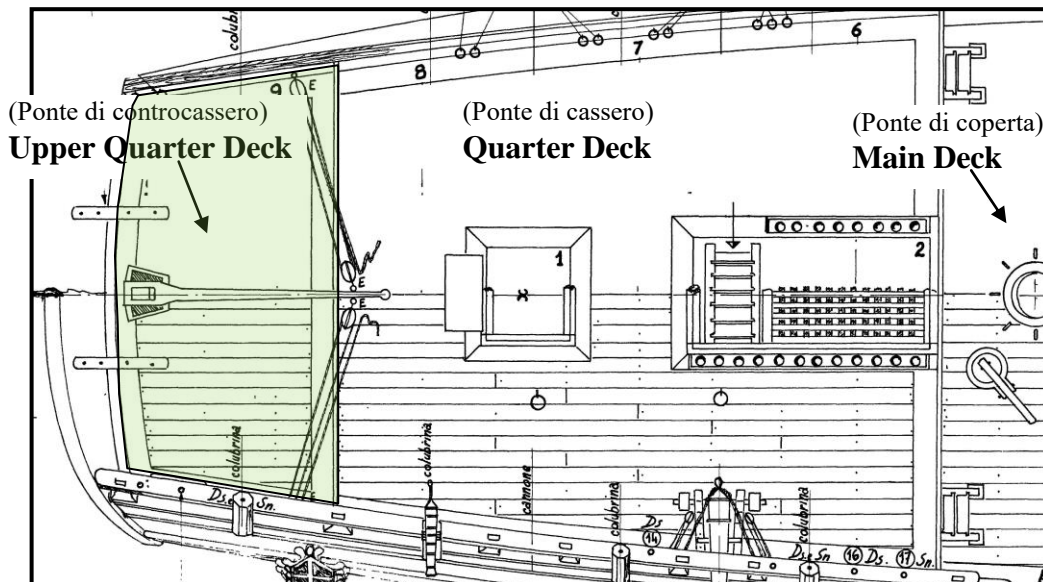

Figure 1: Working Towards a Scratch Model

How *Did* I Build This Ship?

I felt compelled to build this ship from the kit provided but at the same time felt myself drawn to the highly detailed plans which portray far more than the kit provides for. What to do ?

I decided to create a text and photographic portrayal of how the ship could be built from the kit and located in a document on the Euromodel website named '[Lyde Notes](#)'. However, at many points I realised that there were alternative and more detailed construction processes that could be carried out. This usually meant the supply of extra material but having gone to the expense of purchasing the kit, the cost of the extra items was incidental. That degree of accuracy is beyond the scope of any kit but not the avid scratch builder. However ... I found myself continually referring to the plan sheet diagrams and calculating how I might improve upon what is in the kit. Somehow, I suspect every builder will become – to some degree – a 'kit/scratch' builder.

In any case it's essential to exercise patience and attention to detail while constructing this model. Without question this ship must be built with passion. The plans are there, an outline of the fundamental steps are there but in the end the modeller must display a high degree of flair. The plans must be studied at length before beginning because it is there that the builders will develop a 'set of instructions' for themselves. **The kit will not necessarily provide all that is required if the modeller aims to include some of the finer detail.**

The kit WILL enable an excellent model to be built from the materials supplied. The plans must be studied at length before beginning because it is there that the builders will develop a 'set of instructions' for themselves.

A complimentary criticism of Euromodel's kits is that the photos displayed on the internet do not portray the kit contents provided but in fact are scratch models. The simple fact is that there are so many variations and additions to the original design possible that (at the risk of repetition) no two ships are going to look the same. The more you examine the plans, the more you are likely to lean towards the 'scratch' style of construction.

Euromodel appreciates your choosing this product and wishes you a challenging experience. There is no question that the detail provided here on the plans and the material contained in the kit sets Euromodel kits apart from other kits available on the market.

Construction Manual

The following documentation will hopefully assist other future builders an easier pathway of construction. There is no doubt that others will see 'flaws' or better ways of carrying out some step. In the end, there can be no one way of doing anything so please read what I have written and then make your own judgement about the best method for you and your build.

With a limited build-time to create this hull, many might well criticise the quality of construction at some points and you might also be aware that photographing a small area on the hull and enlarging it produces a very different image to the one seen simply through the eye. So whatever you see, make yours better !

Chapter 2: TRANSLATION (from Italian to English)

Whilst every care has been taken with this translation, the author claims little depth of knowledge of Italian and thus various grammar and syntax errors will be apparent to those who are bilingual in these two languages.

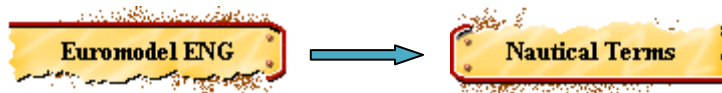

An on-line dictionary is to be found on the Euromodel website – ‘Nautical Terms’ and this will provide assistance for a *large range of terms NOT included in the following pages* of translation from Italian to English.

Tavola 1 VISTA D’INSIEME	Plan Sheet 1 OVERALL DRAWING
Tavola 2 SCAFO COSTRUZIONE	Plan Sheet 2 HULL CONSTRUCTION
BOLZONE	DECK CAMBER
SEZIONI TRASVERSALI (ordinate)	CROSS-SECTION VIEW OF FRAMES
tagliare su ordinata	frame cut-out
SEZIONE LONGITUDINALE sulle mezzana della nave.	LONGITUDINAL SECTION along the centre line of the ship.
linea di costruzione	(see sign convention below)
mezzana nave	(see sign convention below)
SEGNI CONVENZIONALI	SIGN CONVENTION
⊗ or x : mezzana nave	middle of ship
L.C. : linea di costruzione	centerline of construction
Ds. : lato destro della nave	right side of ship
Sn. : lato sinistro della nave	left side of ship
L. : lunghezza	length
l. larghezza	width, breadth
⊙ : diametro	diameter

Tavola 3 STRUTTURE PRINCIPALI	Plan Sheet 3 MAIN STRUCTURE
DIMA del BOLZONE	DECK CAMBER TEMPLATE
Incave sulle ordinate 1-2-3-4-5 per correnti longitudinali	Cut out on the frames 1-2-3-4-5 for the longitudinal stringers
Incave sulle ordinate 6-7-8-9-10 per correnti longitudinali	Cut out on the frames 6-7-8-9-10 for the longitudinal stringers
Legno 2mm. di spessore	2mm. thick plywood
TRACCIATURA del BOLZONE USANDO la DIMA	OUTLINE TO FORM CAMBER TEMPLATE
Centrare la dima su 'x', e puntare sui terminali dell'ordinata tracciata segnando il bolzone e le relative incave	Create the centre line for the template 'x' and at the top of the frame create the outline sketch of camber and the relative cut out.
N.B. la dima e tratteggiata	N.B. the template for the cut-out
curva da tracciare	curve of the camber tracing
DIMA per la LAVORAZIONE della STRUTTURA LONGITUDINALE CENTRALE	SKETCH SHOWING PRODUCTION OF THE CENTRAL LONGITUDINAL STRUCTURE
Cassero/ coperta/ castello	Refer to 'Nautical Terms'
Correnti Ds. e Sn.	Longitudinal stringers
Struttura centrale	Frame (central structure)
N.B. Tagliare sulla linea piena esternamente	N.B. Full view of shaping required for filler blocks
VISTA delle STRUTTURE CONGIUNTE	VIEW OF ASSOCIATED STRUCTURES
Riempimento in legno Ds. e Sn.	Filler block (for stern) in wood
Rivestimento dei ponti cassero,coperta,castello	Positioning of quarter, main & foredecks

Tavola 4 Viste de: POPPA, PRORA e dei PONTI	Plan Sheet 4 Views of the STERN, BOW and of the DECKS
SPECCHIO di POPPA	VIEW OF THE STERN
PONTI: CONTROCASSERO – CASSERO - COPERTA-CASTELLO	POOP, QUARTER, MAIN & FORECASTLE DECKS
BRACCIUOLO no 2 rinforzi	2 reinforcing TAFFRAIL KNEES
anello di ritenuta dell'ostino del picco	ring for guy rope of kicking strap of gaff
anello di ritenuta del bome	ring for boom guy rope
galloccia di ritenuta del bome	cleat for boom guy rope
attachi paranchi per brandeggio cannoni Ds. e Sn.	attach to gun carriage tackle, right & left
attachi funi della culatta Ds. e Sn.	attach to rope of breech (from cannon), right & left
attacco paterazzo volante Ds. e Sn.	attach running backstays, right & left
attachi stralli de maestra	attach stays of main mast
caviglia dell'ostino del pico	belaying pin for gaff kicking strap
golfare per calorna Ds. e Sn.	eye-bolt for lift/ tackle on right & left

VISTA della PRORA	VIEW OF THE BOW
--------------------------	------------------------

Tavola 5 ATTREZZATURE di COPERTA	Plan Sheet 5 MAIN DECK RIGGING
	For many terms, refer to 'Nautical Terms'
Il disegno si riferisce alla gru di destra – Ds. – costruire no. 2 gru.1 Ds. – 1 Sn.	Look at drawing of cathead on the plan for the right side & construct 2 - 1 for left & 1 for right.
VERRICELLO SALPANCORE	WINDLASS WINCH
campana dei quarti	bell (rung every quarter hour)
∅ 1mm. fasciata con cordo ∅0.4mm.	serve to 1mm. thickness with 0.4mm. cord

Tavola 6 albero di MAESTRA, BOME, PICCO e particolari	Plan Sheet 6 DETAIL OF MAIN MAST, BOOMS & GAFF
<ol style="list-style-type: none"> 1. ASTA di CONTRORANDA 2. PICCO + Buttafuori picco di maestra 3. BOME + Buttafuori boma di maestra 	<p>In descending order down the main mast are ...</p> <ol style="list-style-type: none"> 1. GAFF TOPSAIL BOOM 2. MAIN MAST GAFF + Main gaff outrigger 3. MAIN MAST LATEEN + Main boom outrigger
	<p>NOTE:</p> <ol style="list-style-type: none"> a. This sheet only gives detail without instructions for construction. The terms used will be found on the Euromodel website under 'Nautical Terms' b. The <i>pennola del contropicco di maestra</i> is shown on this sheet as simply '<i>pennola del contro</i>'. Both relates to the '<i>Ensign Staff</i>' which carries the Ensign flag.

Tavola 7 albero di TRINCHETTO, PENNONI e PICCO	Plan Sheet 7 DETAIL OF FOREMAST, YARDS & GAFF
<ol style="list-style-type: none"> 1. PENNONE di PARROCCHETTO 2. PENNONE di TRINCHETTO 3. PICCO di TRINCHETTO 	<p>In descending order down the foremast are ...</p> <ol style="list-style-type: none"> 1. FORE TOPSAIL YARD 2. FORE LOWER TOPSAIL YARD 3. FOREMAST GAFF
Calorna – N°. 2 albero maestra – n° 2 albero di trinchetto, una a Ds., una a Sn.	Two tackle to main mast and two tackle to foremast, one each to the left and to the right.
Paranco dell' amantiglio del picco	Lift block & tackle for gaff
Drizza pennone di trinchetto	Hoist for main yard on fore mast
Pianta all' incastro dell'albero di parrochetto	Plan showing the interlocking joint of the fore lower topsail mast with the lower mast

Amantiglio del picco	Gaff lift
Alla cavigliere	To the pin rail

Tavola 8 BOMPRESSO, NODI e PARTICOLARI	Table 8 BOWSPRITS, KNOTS & ROPE DETAILS
tirando il nodo stringe	pull knots tightly
caspargere di colla e stringere forte il nodo	spread with glue & tighten knot strongly
N.B. Incava da farsi in corrispondenza delle posizioni dove devono essere fissati i bozzelli, cioè sui ... etc	Notch to be carved at locations where there are attached blocks – namely on yards, booms, gaffs, etc
nodo per cavo ancora	knot for anchor rope
nodo chiuso	knot closure
cavo guernito	rope seizings
inferitura con cavo	furling line
cavo d'inferitura	furling line rope
BOZZELLI	BLOCKS
con stroppo in ferro	with iron strap
con stroppo in fune (usare per il modello)	with rope strap (used by the modeler)
SARTIE	SHROUDS
	<i>'To be completed at a later date'</i>
STRALLO	STAYS
1° strallo di trinchetto	Primary foremast stay rope
strallo di trinchetto a una sola braca	Foremast stay rope is one single rope
2° strallo di trinchetto	Secondary foremast stay rope
strallo maestra a due brache	Main mast stay consists of two ropes
gerli d'inferitura	furling line gaskets
bugna d'inferitura	clew of furling line
branche (patte) di bolina	branch of bowline
BOMPRESSO e ASTA di FIOCCO	BOWSPRIT & JIBBOOM
	<i>'To be completed at a later date'</i>

Tavola 9 MANOVRE e PARTICOLARI	Plan Sheet 9 ARRANGEMENT & DETAIL_(of rigging)
DORMIENTI nere	STANDARD RIGGING (black)
	[For description of terms, refer to the on-line 'Nautical Terms' - Euromodel website]
MANOVRE CORRENTI colori naturali	RUNNING RIGGING (natural colour)
1. drizza di gola del picco 2. drizza di penna del picco 3. imbroglio di randa 4. imbroglio di randa 5. amantiglio dell'asta di controranda 6. drizza della vela di strallo 7. brancarella delle mura di controranda 8. amantiglio del bome 9. scotta di controranda 10. drizza della pennola di contro 11. '5' ..brancarella della vela di strallo	1. hoist for gaff throat 2. hoist for gaff boom 3. lazy jacks of main sail 4. lazy jacks of main sail 5. lift for gaff sail boom 6. hoist for stay sail 7. cringle for gaff topsail & tack 8. boom lift 9. gaff topsail sheet 10. hoist for boom jumper stay 11. '5' ... cringle for stay sail
cavigliera di MAESTRA	MAIN MAST PIN RAIL
	Refer to translations above
cavigliera di TRINCHETTO	FOREMAST PIN RAIL
carica scotte della vela di parrocchetto alabasso della vela di parrocchetto (scotta) amante di terzarolo amantiglio del pennone di trinchetto brancarella della vela di strallo amantiglio del pennone di parrocchetto imbroglio di randa drizza di penna del picco brancarella della randa drizza del pennone di parrocchetto drizza di gola del picco alabasso vela di strallo – imbroglio di randa amantiglio del pennone di parrocchetto brancarella della vela di strallo amantiglio del pennone di trinchetto amante di terzarolo alabasso della vela di parrocchetto (scotta) carica scotte della vela di parrocchetto drizza del pennone di trinchetto	clewline of lower topsail downhaul rope (sheet) for fore lower topsail tie-pendant of reef lift for main yard cringle of main stay sail lift for topsail yard lazy jacks of main foresail hoist for gaff boom cringle of for main sail hoist for fore topsail yard hoist for gaff throat main stay sail downhaul rope – lazy jacks of main sail lift for topsail yard cringle of main stay sail lift for fore main yard tie-pendant of reef downhaul rope (sheet) for fore lower topsail clewline of lower topsail hoist for for main yard
vele di: randa t. – strallo - controranda e contro	Sails of : Fore Lower, Stay, Gaff Top & Jumper Stay
(vele di:) trinchettina e fiocco	Sails of : Fore Stay & Jib
vela di parrocchetta	Fore Topmast Sail
N.B. Le vele vanno rilevate dalla "Vista d'assieme" tav. 1	Relative positions of the sails are best determined by referring to Plan Sheet 1
Si consigliano funi di lino	We suggest that ropes be made from flax
14. drizza di trinchettina	14. hoist for fore stay sail
15. drizza del fiocco	15. hoist for jib sail
16. bracci del pennone di parrocchetta	16. fore upper topsail brace
17. bracci del pennone di trinchetto	17. fore stay brace
18. scotta di trinchettina	18. fore stay sail sheet
19. scotta di fiocco	19. jib sheet
20. alabasso di trinchettina	20. fore stay sail downhaul rope
21. alabasso del fiocco	21. jib sail downhaul rope
22. patte di bolina	22. bow line bridle

Chapter 3: THE KIT

Drawings

The diagrams are beautifully drawn and would allow a scratch-built kit to be readily developed. The difficulty is to separate the essential detail necessary to build the kit from the other more seriously accurate detail. The drawings depict a ‘sandwich’ of THREE timbers to

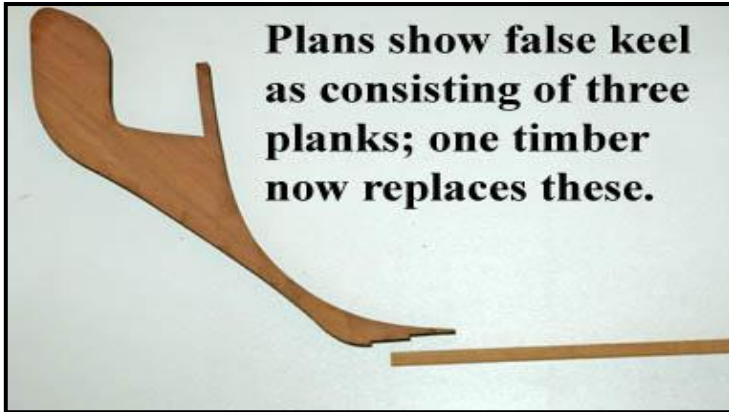

Figure 2: A Difference !

form a false keel. However, in this kit we have ONE piece of timber 6 x 10 mm. The base of the elaborate bow post that is pre-cut allows for these three timbers in a stepped configuration so the modeller must cut a complementary housing into the stem post supplied to accommodate the single piece.

Metal Decorations



Figure 3: Metal Identification

All cast metal decorations are contained in small but unmarked plastic packets. They have very few blemishes to remove. On the reverse side of the casting there is a specific number that identifies that piece. There are some excellent side and stern views on pages in the instructional booklet or CD that allows the kit builder to identify the castings with little problem.

Now is the time to go through every packet, identify the pieces. What I then did was to place an identifying name or number inside each packet and re-staple them ready for future use.

Much patience is required to identify these pieces and I would caution against direct contact with the skin – use gloves when cleaning & painting the pieces. Certainly any filing should be carried out in a separate area that can be easily cleaned up. Obviously any painting and gilding will need to be done before assembly onto the ship. More on their usage later.

Scrap Material

The laser-cut material in this kit is surrounded by pieces of wood which may appear to be superfluous – do not discard this ‘waste’ as there will be a number of places in the ship build where it becomes useful.

Component List

Laser-cut

Keel (1) – Chiglia

Transverse Frames (10) - Ordinate

Main Deck (1) - Ponte di coperta

Quarter Deck (1) – Ponte di cassero

Forecastle Deck (1) – Ponte di castello

Support Cradle (2) - Invasature



Limewood – Listello tiglio

30 x 40 x 220 mm.(1) **Filler Blocks for Bow & Stern** - Riempimenti di poppa e di prua
1.5 x 6 x 570 mm. (50) **First Planking** - 1° Fasciame

Wood –Walnut – Listello noce

1 x 6 x 570 mm. (50) **Second Planking** - 2° Fasciame
0.5 x 4 x 500 mm. (30) **Deck Planking** - Rivestimento ponti
6 x 10 x 500 mm. (1) **False Keel** – Sottochiglia; **Stern Stem Post** – Dritto di poppa
2 x 8 x 570 mm. (2) **Wales** – Incintoni
2 x 2 x 570 mm. (2) **Wales** – Incintoni
2 x 5 x 570 mm. (2) **Cap Rail** – Capodibanda
2 x 4 x 570 mm. (2) **Cap Rail** – Capodibanda
5 x 15 x 500 mm. (2) **Longitudinal Stringers** – Correnti longitudinali
10 x 10 x 220 mm. (1) **Cradle Support Cross Pieces** – Traversa per invasatura
5 x 5 x 500 mm. (1) **Pin Rail & Culverins Supports** – Pazienza e supporto colubrine
1.5 x 25 x 350 mm.(1) **Channels** – Parasartie
2 x 5 x 570 mm. (1) **Waterway** - Trincarino

Accessories

Anchors 40 mm. with ring & stocks (2) - Ancora da mm. 40 con ceppi ed anelli (Art. 11/009)

Bell (1) – Campana (Art. 11/107)

Belaying Pins (40) – Caviglie (Art. 11/005)

Blocks

I: 3mm., 1 hole(10) - Bozzelli da mm. 3 a 1 foro (Art.22/026)

H: 4mm., 2 hole(3) - Bozzelli da mm. 4 a 2 foro (Art.22/031)

E: 5mm., 1 hole (31) - Bozzelli da mm. 5 a 1 foro (Art.22/028)

F: 5mm., 2 hole (12) - Bozzelli da mm. 5 a 2 foro (Art.22/032)

A: 7mm., 1 hole (20) - Bozzelli da mm. 7 a 1 fori (Art.22/030)

B: 7mm., 2 hole (14) - Bozzelli da mm. 7 a 2 fori (Art.22/034)

D: 8mm., 3 hole (8) - Bozzelli da mm. 8 a 3 fori (Art.22/040)

Capstan (1) – Aragano (con 2 supporti mm. 4x20x80) (Art.22/010)

Chain Plates (16) - Landra (Art.11/306)

Cleats (13) – Gallocce (Art.11/010)

Crosstree with Main Cheek (1) – Crocetta con maschette di maestra (Art. 22/057)

Crosstree with Foremast Cheek (1) – Crocetta con maschette di trinchetto (Art. 22/058)

Culverins, complete (12) – Colubrine complete (Art. 11/001)

Deadeyes,7 mm. (32) - Bigotta da mm. 7 (Art.22/022)

Deadeyes, 4 mm. (16) - Bigotta da mm. 4 (Art.11/019)

Flags (2) - Bandiere (Art.13/033 & 13/023)

Grating 40 x 40mm (1) - 30 mm.(207) - paiolato da mm. 40 x 40 (Art.22/003.01)

Guns:

Cannons with Carriages (4) – Cannoni con affusti (Art.11/015)

Wheels (16) - Ruote per cannoni (Art. 22/001)

Axles for cannon wheels,40mm. (1) – Spina per ruote cannoni mm. 40

Ladders, complete (2) – Scala complete (Art. 22/002.01)

Ship's Boat ('cutter') (1) -120 mm. Scialuppa (Art.88/02)

Mast Caps – Testa di moro ...(Art.22/054) (1) – Buttafuori del bome; (Art.22/055) (3) – Maestra e trinchetto
bompreso/ Main mast, Foremast & Bowsprit

e

Metal Castings ..

Transom (1) – Specchio di poppa in fusione (Art. 33/001)

Right Window (1) – Finestrella destra in fusione (Art. 33/002)

Left Window (1) – Finestrella sinistra in fusione (Art. 33/003)

Name Base Plate (1) – Targhetta per invaso (Art. 12/001)

Plans Set (10) - Serie disegni (No 10 Tavole) (Art.66/001)

Pump (2) – Pompa (Art. 22/102)

Rigging yarn

0.25 mm. (Art. 77/025)/ 0.40 mm. (Art. 77/040)/ 0.80 mm. (Art. 77/080) / 1.00 mm. (Art. 77/100) /
1.50 mm. (Art. 77/150)

Rudder Hinges & Pins (3) - Cerniere timone complete di perni (Art.11/007)

Sail Cloth: 500 x 900 mm. (1) - Serie tela per vele mm. 500 x 900mm.

Spars: 12 x 510 mm. (1), 12 x 470 mm. (1); 10 x 220 mm. (1); 8 x 550 mm. (1); 8 x 270 mm. (1); 6
x 420 mm. (2); 5 x 500 mm. (1); 5 x 210mm. (1); 3 x 310mm. (1)

Instructions - Istruzioni

Chapter 4: MORE ADVANCED IDEAS

The following ideas are extensions that might be used by more experienced builders. In no way are they intended to be prescriptive for a basic build.

Measurements

The following commentary is about taking things to an extreme 'measure' and only represents a whim that I decided to follow.

Maybe very few builders will ever go this extent ... but in order to interpret the plan drawings of the hull side view, it should be remembered that the drawings are a three-dimensional view shown in two dimensions. Allowances could be made for this 'abberation'. The changes in dimension will be small and if this change is not followed, things will still fit into place. This particularly relates to ports and the wales.

Remember though, the position of the ports was established early in the construction of the hull so what follows, for most, will be superflous !

These techniques allows for a closer reproduction of that shown in the plan drawings.

Fig. 4 indicates how the bottom edge position of the port might be determined.

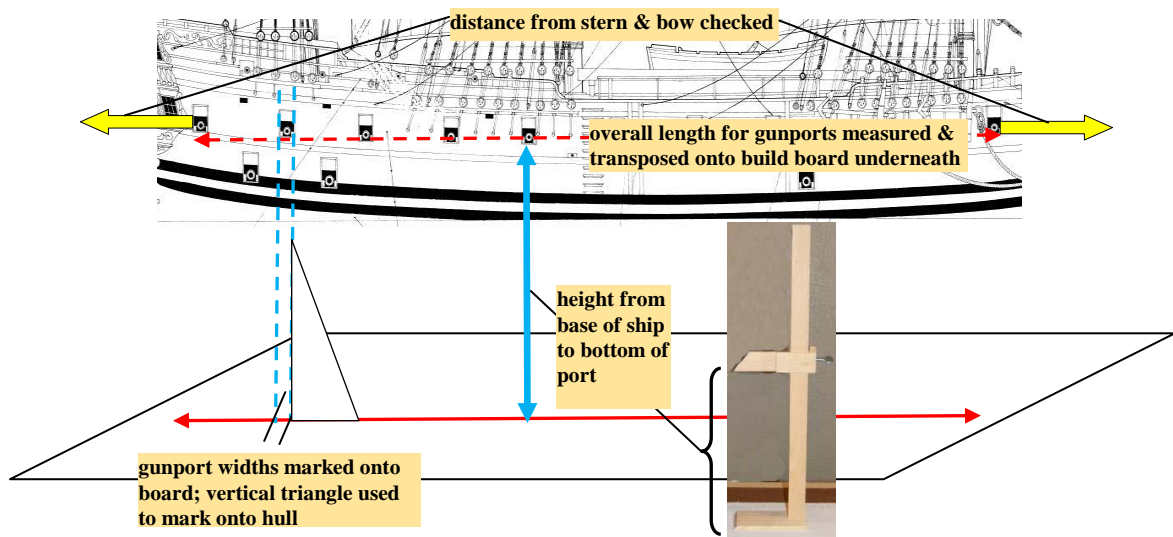

Figure 4: Establishing Gunport Positions

One aspect to double check on is the width of the ports as the bow curves – particularly the end port (chase port). On the drawings, these will appear to narrow due to their being a three-dimensional representation. In fact, all ports will have the same width.

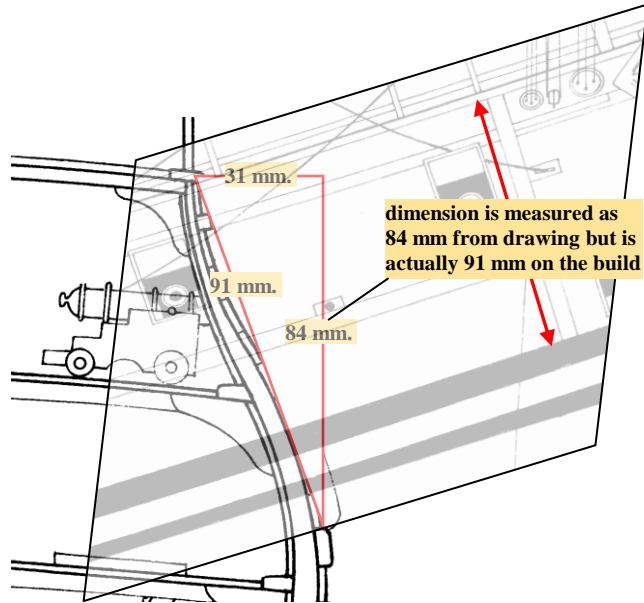

Figure 5: Making Adjustments for Three Dimensions

Fig. 5 illustrates a common problem faced by builders – the drawing illustrates what is *seen* but not what is *measured* ... it is a three-dimensional view presented as a two-dimensional view.

The figures shown in Fig. 5 were taken straight off the computer screen but the *ratio of figures will remain the same*.

84 mm. from the drawing is actually 91 mm. on the model.

For gunport and wale readings, the figures obtained would be multiplied by 91/84.

(i.e. increasing measurements by a factor of **1.083**)

e.g. **28 mm.** becomes $28 \times 91/84 = 30 \text{ mm.}$

Treenail (or trenail, trennel or trunnel)

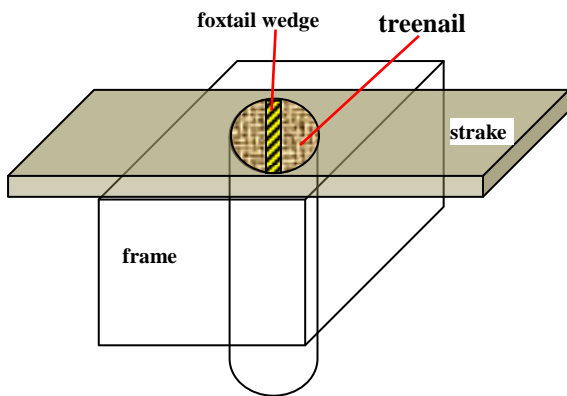

Figure 6: Diagrammatic View of Treenail

Instead of using metal fasteners to fix planks to the frames, it was common to do treenailing. This consisted of inserting wooden 'pegs' which were of a softer wood, into drilled holes and then expand their outer end with a wedge of much harder wood driven into them called a foxtail wedge. When the ship was immersed in water, the wooden pegs would swell and further tighten the pegs. This method worked extremely well to maintain the ship's physical integrity.

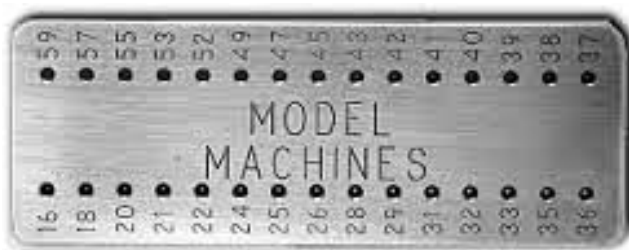

Figure 7: Byrne's Draw Plate

In ship modelling, it is common to manufacture these treenails from bamboo barbecue sticks by splitting them along their length and then passing them through a draw plate to create a specific diameter.

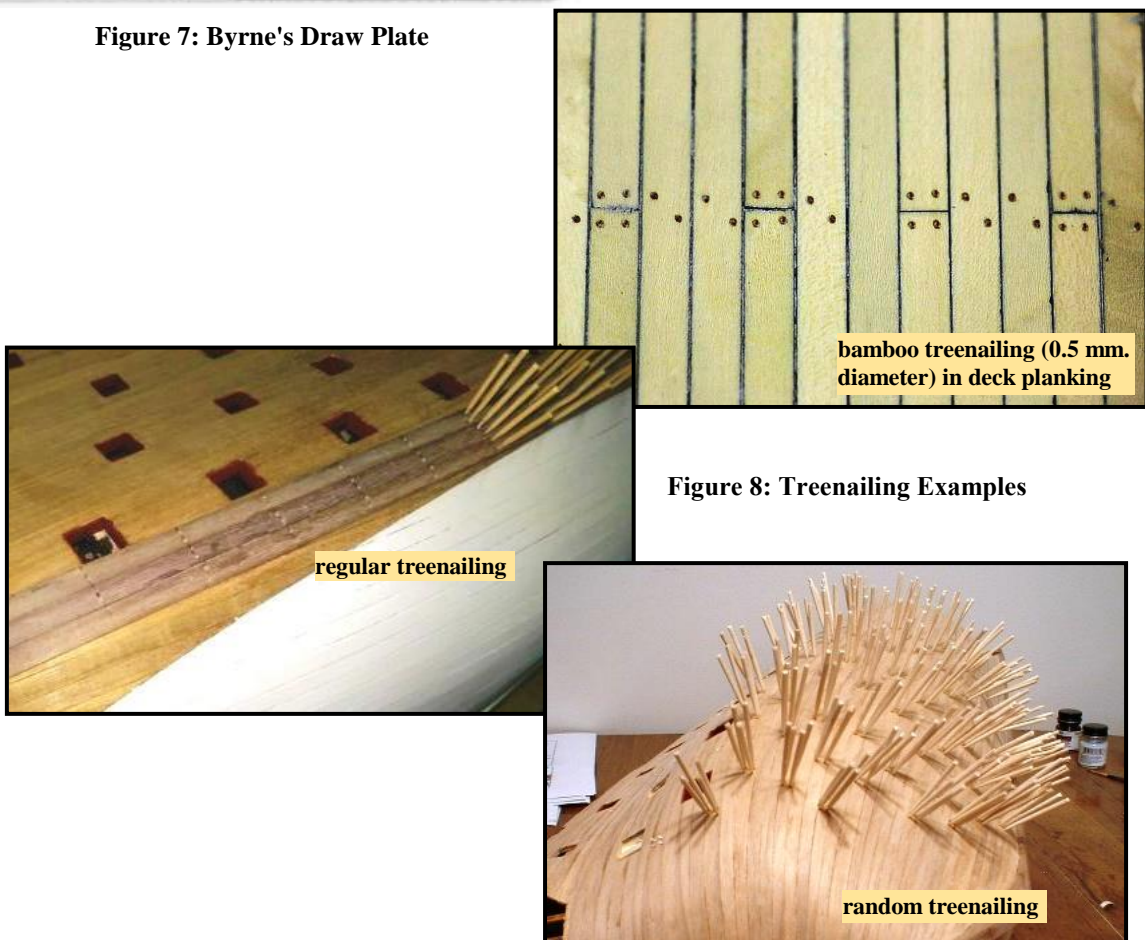

Figure 8: Treenailing Examples

Rigging Tool

A gift came from Canada that contained this combination of a needle threader and a looper threader ... really fantastic to use. The threader is approx. 135 mm. in length which makes it a very handy length when getting amongst all the rigging.

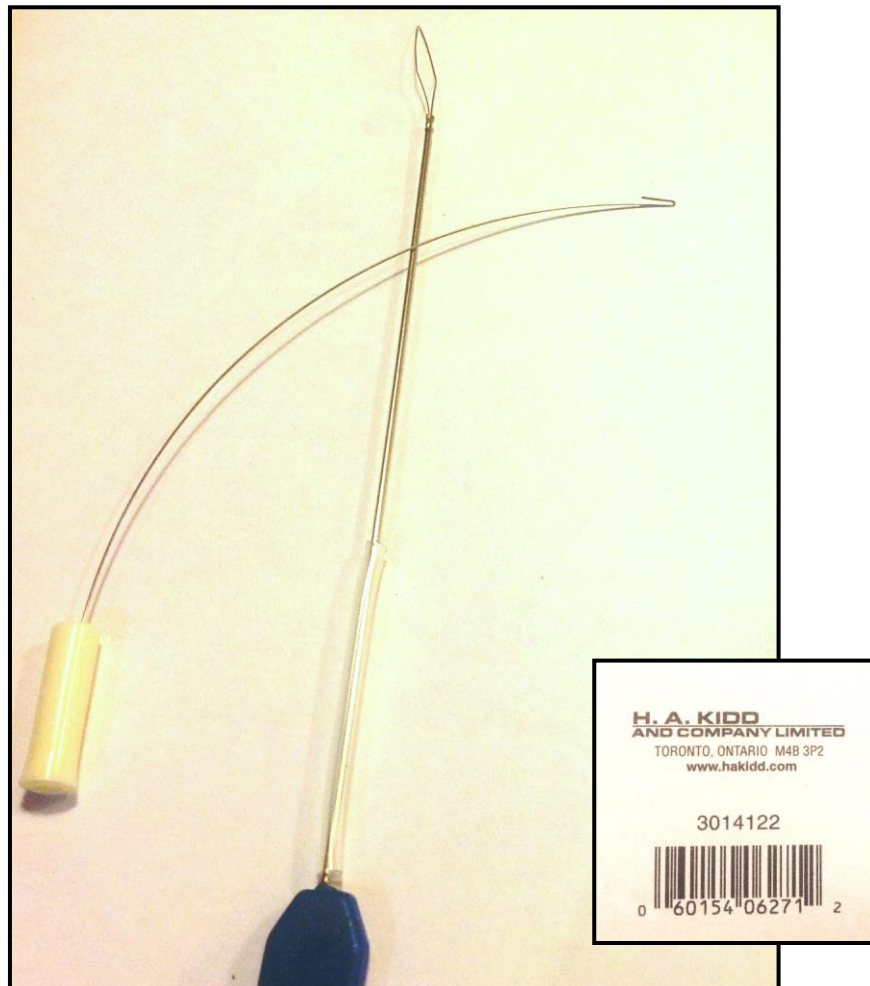

Figure 9: Two Rigging Tools

Plank Bending

I like this machine although I do not have one (as yet). From the Micro-Mark Catalogue comes the following description ...

‘ Professional Quality Bending Machine Forms Smooth Curves in Wood, Plastic and Metal’

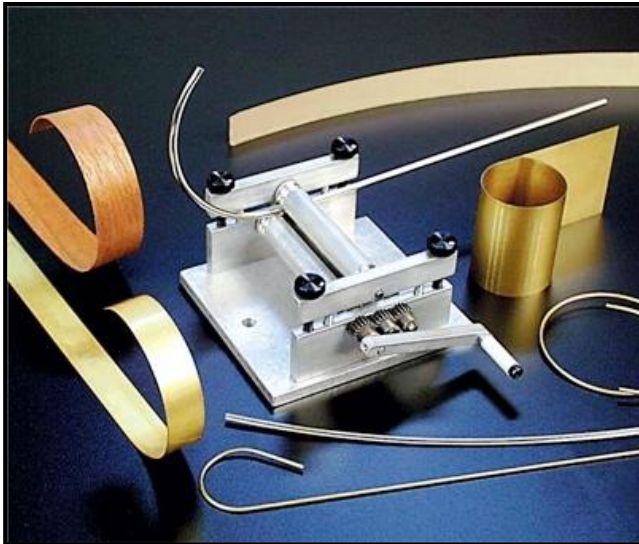

Figure 10: Micro-Mark Bending Machine

‘There's never been a better, easier-to-use tool for making perfect bends in ship model planking. *Works on wood strips up to 2-1/4 inches (approx. 57 mm.) wide and 1/8 inch (approx. 3 mm.) thick...even plywood!* Simply set the rollers for the desired radius and turn the crank to feed and form the material. Precision machined of aluminum with steel gears. Rollers are 1/2 inch (12.7 mm.) diameter by 3 (76.2 mm.) inches long.’