

## TRANSLATION LINKS

1. type into your browser ... **english+italian+glossary+nautical terms**
2. utilise the translation dictionary ‘Nautical Terms & Expressions’ from Euromodel website

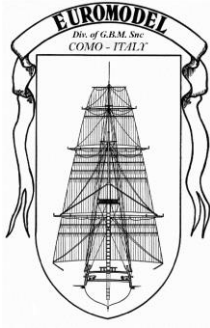

# Resources for the La Renommée

This resource information file was based on the original text supplied by Euromodel and then expanded in detail as the actual ship was constructed by the author, Peter Coward.

Whilst relating to the basic build of this ship, there is information in Chapter 4 that is for the advanced builder who may wish to pursue more detailed work.

Neither the author nor Euromodel have any commercial interest in this information and it is published on the Euromodel web site in good faith for other persons who may wish to build this ship. Euromodel does not accept any responsibility for the contents that follow.

# La Renommée



# Contents

*[To navigate through the contents – use ‘control + click’]*

Euromodel Preview .....	5
Chapter 1: INTRODUCTION .....	6
Historical Notes.....	6
Construction Philosophy .....	7
Kit Building versus ‘Scratch’ Building.....	7
How <i>Did</i> I Build This Ship? .....	8
Kit Variations.....	9
Chapter 2: TRANSLATION (from Italian to English) .....	10
Chapter 3: THE KIT.....	20
Drawings .....	20
Component list.....	21
Wood – Laser-cut.....	21
Limewood – listello tiglio .....	21
Plywood- compensata .....	21
Walnut – listello noce .....	21
Accessories.....	22
Chapter 4: BASIC CONCEPTS EXPLAINED .....	24
Chapter 5: MORE ADVANCED IDEAS .....	25
Measurements .....	25
Treenail (or trenail, trennel or trunnel) .....	27
Rigging Tool .....	28
Plank Bending.....	29

## Illustrations

[These figures are not hyperlinked]

Figure 1: Model of LaRenommee; Rear View.....	6
Figure 2: Model of LaRenommee; Front View.....	6
Figure 3: Sectional View of Decks from Plan Sheet.....	7
Figure 4: Capstan, Scratch Detail.....	7
Figure 5: Organisation of Plan Sheet Material.....	20
Figure 6: Stem Post Detail Which You Might Use.....	20
Figure 7: Identification of Metal Parts .....	20
Figure 8: Bulwark Height Correction .....	24
Figure 9: Establishing Gunport Positions .....	25
Figure 10: Making Adjustments for Three Dimensions .....	26
Figure 11: Diagrammatic View of Treenail .....	27
Figure 12: Byrne's Draw Plate .....	27
Figure 13: Treenailing Examples.....	27
Figure 14: Two Rigging Tools.....	28
Figure 15: Micro-Mark Bending Machine.....	29

# Euromodel Preview

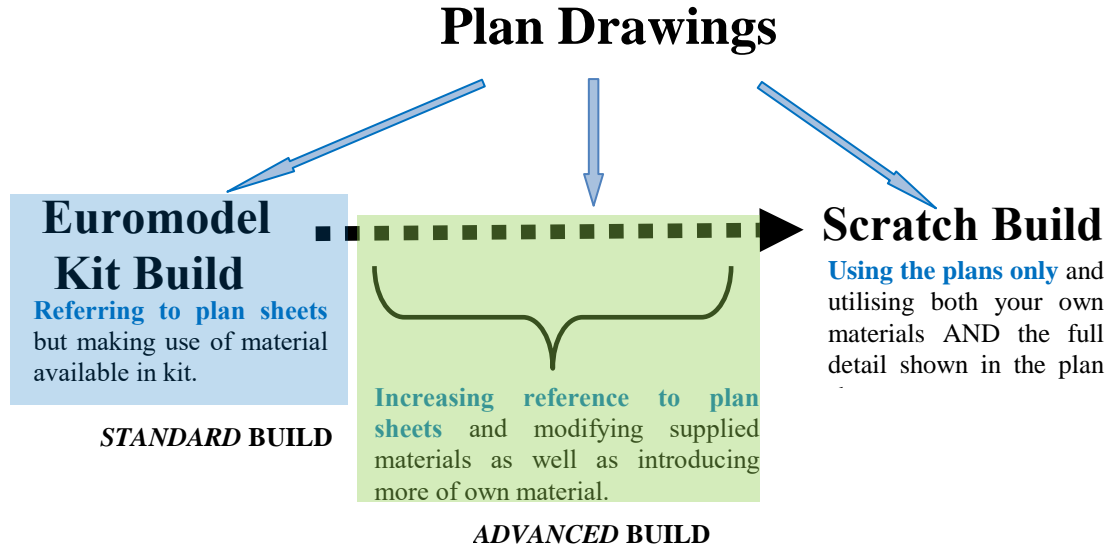

Euromodel kits are based on sets of drawings by a naval architect and contain a comprehensive amount of detail that would be a challenge to the most serious ship modeler. This is in contrast to most other kits that whilst they also contain excellent plans, the intention there is to achieve a build similar to the plans provided. Euromodel offers plans that can be interpreted at various levels of complexity. If the builder has limited experience in the craft of shipbuilding, then the plans can be read at a simplistic level.

**Whilst *all* plan drawings are important to the construction of the La Renommée, the builder is well advised to focus on three – Plan Sheets 2, 5 and 17**

It could well be argued that *the outcome is somewhere on the continuum between a standard model construction and a scratch model*. How far you wish to extend this continuum is up to you and your build of this ship will be determined by the degree of complexity you choose (refer to the diagram above).

The kit material will go a long way towards achieving a good model but be aware that the purchase of some extra material might be necessary depending on how far you wish to go in emulating the plans. There will be little left over from the kit contents, but during the construction you should experience a compelling drive to create something better than the basic model. Euromodel is aware of this challenge and so provides just the basic needs and leaves it up to the modeller to determine how far he will extend his skills.

***In summary ... my comments are not prescriptive and if the detail is sometimes a little too precise, please do not let this deter you. It will be up to you to take as much information as you wish and the rest to 'throw overboard'. It is your model, your creation, your handiwork.***

# Chapter 1: INTRODUCTION

## Historical Notes

in



Figure 1: Model of LaRenommee; Rear View

There were two Renommée's built in France, one in the 17<sup>th</sup> Century and this one in the 18<sup>th</sup> Century. Launched 1744 at Brest, La Renommée was a one-off 40-gun ship designed by Antoine Grognard with 30 12-pounders and 10 8-pounder guns. She was captured by the British Navy (HMS Dover) 27 September, 1747 and converted into a 30-gun fifth-rate frigate as the HMS Renown and served until she was broken up in 1771. However, this type of frigate is very important in the evolution of ships of the British Navy because it inspired the development of a series of fifth-rate frigates equipped with only thirty guns of large calibre, all placed on the second deck.

Details for this ship have relied on Chapman's book, 'Architectura Navalis Mercatoria'



Figure 2: Model of LaRenommee; Front View

### EUROMODEL

Euromodel Division of the GBM Snc di Mazza Massimo & C.  
Via Aldo Galli, 11  
22100 COMO (CO)  
ITALY

e-mail : [euro@euromodel-ship.com](mailto:euro@euromodel-ship.com)  
home page <http://www.euromodel-ship.com>

Any submitted photos & comments will become the property of  
Euromodel Division of the GBM Snc di Mazza Massimo & C



## How *Did* I Build This Ship?

I felt compelled to build this ship from the kit provided but at the same time felt myself drawn to the highly detailed plans which portray far more than the kit provides for. What to do ?

I decided to create a text and photographic portrayal of how the ship could be built from the kit and located in a document on the Euromodel website named '[LaRenommee Notes](#)'. However, at many points I realised that there were alternative and more detailed construction processes that could be carried out. This usually meant the supply of extra material but having gone to the expense of purchasing the kit, the cost of the extra items was incidental. For these alternative processes, you will see some words or heading that state 'Alternative 1' or 'Alternative 2'

A good example is shown by the two ship's capstans on Plan Sheet 6. The immense detail provided will enable the construction of the capstans along with the ratchet mechanisms. That degree of accuracy is beyond the scope of any kit but not the avid scratch builder. However ... I found myself continually referring to the plan sheet diagrams and calculating how I might improve upon what is in the kit. Somehow, I suspect every builder will become – to some degree – a 'kit/scratch' builder.

In any case it's essential to exercise patience and attention to detail while constructing this model. Without question this ship must be built with passion. The plans are there, an outline of the fundamental steps are there but in the end the modeller must display a high degree of flair. The plans must be studied at length before beginning because it is there that the builders will develop a 'set of instructions' for themselves. **The kit will not necessarily provide all that is required if the modeller aims to include some of the finer detail.**

The kit WILL enable an excellent model to be built from the materials supplied. The plans must be studied at length before beginning because it is there that the builders will develop a 'set of instructions' for themselves.

**A complimentary criticism of Euromodel's kits is that the photos displayed on the internet do not portray the kit contents provided but in fact are scratch models. The simple fact is that there are so many variations and additions to the original design possible that (at the risk of repetition) no two ships are going to look the same. The more you examine the plans, the more you are likely to lean towards the 'scratch' style of construction.**

Euromodel appreciates your choosing this product and wishes you a challenging experience. There is no question that the detail provided here on the plans and the material contained in the kit sets Euromodel kits apart from other kits available on the market.

## Construction Manual

The following documentation will hopefully assist other future builders an easier pathway of construction. There is no doubt that others will see ‘flaws’ or better ways of carrying out some step. In the end, there can be no one way of doing anything so please read what I have written and then make your own judgement about the best method for you and your build.

With a limited build-time to create this hull, many might well criticise the quality of construction at some points and you might also be aware that photographing a small area on the hull and enlarging it produces a very different image to the one seen simply through the eye. So whatever you see, make yours better !

**This manual is a real ‘ship-building in progress’ and unlike other similar texts, the non-publication-type photographs show the raw work as it is being done .**

### Kit Variations

**The serious modeller, of course, can make a myriad of changes and material substitutions.**

**The choice is theirs.** As an illustration, here are a number of changes possible – but the list could go on and on ...

1. The gun carriages supplied do not really match the dimensions or shape shown in the plans. Whilst labour intensive and time consuming, there is much you can do to alter these gun carriages. What a challenge !
2. The anchor piece dimensions could be altered to more suit the diagrammatic dimensions.
3. The decks were traditionally well-scrubbed and lighter in colour than the planking on the hulls. The kit supplies walnut but you could elect to choose a lighter coloured wood.
4. Different woods are available from suppliers for constructing masts & yards but the kit timber supplied is of excellent quality.

## Chapter 2: TRANSLATION (from Italian to English)

Whilst every care has been taken with this translation, the author claims little depth of knowledge of Italian and thus various grammar and syntax errors will be apparent to those who are bilingual in these two languages.

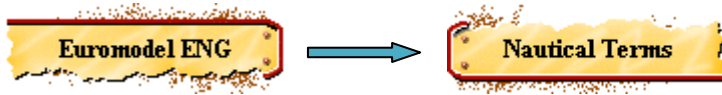

An on-line dictionary is to be found on the Euromodel website – ‘Nautical Terms’ and this will provide assistance for a *large range of terms NOT included in the following pages* of translation from Italian to English.

(a number of terms shown on the Plan Sheets but not included in the lists below can be located on the Euromodel website where a translation of ‘Nautical Terms’ exists)

<b>Tavola 1</b> <b>VISTA DI ASSIEME</b>	<b>Plan Sheet 1</b> <b>OVERALL DRAWING</b>
<b>Tavola 2</b> <b>VISTE ESTERNE SCAFO E SPACCATO</b>	<b>Plan Sheet 2</b> <b>HULL – OVERALL &amp; CROSS SECTION</b>
<b>SEZIONE LONGITUDINALE DA TRIBORDO</b>	<b>LONGITUDINAL SECTION OF THE HULL ON STARBOARD SIDE</b>
Listello mm. 2x2 rete non compressa nella scatola	Timber 2x2mm not included: modeller may choose to include the net (not provided) to produce a better finish.
<b>SPACCATO LONGITUDINALE</b>	<b>LONGITUDINAL (INTERNAL) DETAIL (OF HULL)</b>
<b>SPECCHIO DI POPPA</b>	<b>DETAIL OF THE TRANSOM</b>
<b>VISTA DI PRORA</b>	<b>VIEW OF THE BOW, WITH BOW WORKS &amp; FIGUREHEAD</b>
<b>Tavola 3</b> <b>CHIGLIA E ORDINATE</b>	<b>Plan Sheet 3</b> <b>KEEL &amp; FRAMES</b>
<b>SEZIONE LONGITUDINALE SULLA &amp; DELL’OSSATURA DELLO SCAFO</b>	<b>LONGITUDINAL SECTION OF RIGHT SIDE OF HULL SHOWING FRAMES</b>
Spessore mm. 1	Thickness 1 mm.
<b>ASPORTARE LA PARTE TRATTEGGIATA DOPO AVER ... ETC</b>	<b>SHADED AREA TO BE CUT AWAY FROM THE FRAME</b>

<b>Tavola 4</b> <b>SCHIZZI FUORI SCALA BANDIERE</b>	<b>Plan Sheet 4</b> <b>PERSPECTIVE DRAWINGS OF EXTERNAL VIEWS; FLAGS</b>
<b>SCHIZZO DELLO SPECCHIO DI POPPA</b>	<b>SKETCH SHOWING STERN ORNAMENTATION</b>
<b>SCHIZZO DEL GIARDINETTO</b>	<b>SKETCH OF QUARTER GALLERY</b>
<b>PARTICOLARE DELLA FINESTRATURA ...</b>	<b>WINDOW DETAILS OF QUARTER GALLERY</b>
<b>PARTICOLARE DELLA FINESTRA</b>	<b>WINDOW DETAIL</b>
<b>SCHIZZO DELLA POLENA</b>	<b>SKETCH OF FIGUREHEAD</b>
<b>PORTELLI DEI CANNONI</b>	<b>CANNON GUNPORT DETAIL</b>
<b>DETTAGLIO DELLA SISTEMAZIONE ....</b> Il cavo di grippia e le gomene delle ancore devono essere tinti marrone scuro per simulare catramatura  Cavo di grippia mm. 0.5 Serrabozze mm. 0.25	<b>ARRANGEMENT OF THE ANCHOR</b> ‘The anchor support rope & anchor cable must be coloured dark brown to simulate tarring’. <b>My recommendation is NOT to colour the ropes in keeping with historical reality.</b>  Anchor support rope, 0.5 mm. Anchor support rope 0.25 mm.
<b>SCHIZZO PROSPETTICO PORTE ....</b> Blochetti in ‘cirmolo’ da sagomare a cura del modellista – rivestire all’esterno con listelli di ... Ricavare da blochetto mm 25x28x120	<b>PERSPECTIVE: QUARTER DECK ENTRANCE</b> Block of obeche to be shaped with curves and then covered with 0.5x4 mm. walnut timber. Obtained from a block (of obeche) 25x28x120 mm.

<p style="text-align: center;"><b>Tavola 5</b> <b>PIANTA – SEZIONI E</b> <b>PARTICOLARI</b></p>	<p style="text-align: center;"><b>Plan Sheet 5</b> <b>DRAWINGS – CROSS SECTION</b> <b>DETAIL</b></p>
<p><b>PONTE DI COPERTA</b> (compensata spess. mm. 2)</p>	<p><b>MAIN DECK</b>, 2mm. thickness</p>
<p><b>PONTE DI BATTERIA</b> (compensata spess. mm. 2) Listelli in tanagerica (mm. 0.5x4 )</p>	<p><b>BATTERY DECK</b>, 2mm. thickness Deck planking (now from walnut timber) 0.5x4 mm.</p>
<p><b>SEZIONE AA / BB</b></p>	<p><b>SECTION AA (OR BB)</b></p>
<p><b>PONTE DI CASSERO</b> (compensata mm. 2)</p>	<p><b>QUARTER DECK</b>, 2mm. thickness</p>
<p><b>PEZZO DA 4 LIBBRE (fuori scala)</b> Particolare cerniera (fuori scala) Paranco di rinculata Paranco del cannone Braca</p>	<p><b>4-POUNDER GUN (not to scale)</b> Hinge detail (not to scale) Recoil block &amp; tackle Gun block &amp; tackle Sling</p>
<p><b>DETTAGLIO DELLA GRU DI CAPONE ...</b> Paranco di capone mm.0.3 Amante della gru di capone (cavo 0.75, fasciato ...etc Nodo amante della gomina dell'ancora Bozzello tipo '3H' Stropo e gancio in acc. Cicala dell'ancora</p>	<p><b>DETAIL OF CAT-HEAD (not to scale)</b> Cat-head tackle Cat-head stopper Fisherman's knot attaching rope to anchor 3-hole block Tackle hook Showing 'puddening' the anchor ring with tarred cloth, rope &amp; yarn</p>

<b>Tavola 6</b> <b>PARTICOLARI ATTREZZATURE</b> <b>DI COPERTA</b>	<b>Plan Sheet 6</b> <b>DETAIL OF MAIN DECK EQUIPMENT</b>
<b>ARGANO</b> Part. degli scontri Tratto a sez. Quadra Aspe	<b>CAPSTAN</b> Ratchet detail This is a square cross section Capstan arm
<b>SCIALUPPA</b>	<b>LIFE BOAT</b> Refer to Euromodel ‘nautical terms’ for translations
<b>POMPA DI SENTINA</b> Non compressa nella scatola di montaggio Da realizzarsi a cura del modeller	<b>BILGE PUMP</b> Not included in the kit. To be made by modeler
<b>ARAGANO DI TONNEGGIO</b>	<b>MAIN CAPSTAN</b>
<b>CANOTTO</b> * non compressa ...etc_	<b>DINGHY</b> * Not included in this kit). Refer to ‘nautical terms’ for translations
<b>RUOTA DEL TIMONE</b>	<b>SHIP’S WHEEL</b>
<b>CHIESUOLA DELLA BUSSOLE</b> Scala 2:1 Lato ruota del. Timone Lampada, cassetti, ripostigli Bussole con snodo cardanico Da realizzarsi a cura del modellista	<b>COMPASS BINNACLE</b> Scale 2:1 Adjacent to ship’s wheel Refer to Euromodel ‘nautical terms’ Universal joint supporting compass To be made by the modeler
<b>ARTIGLIERIA DA 12 LIBRE</b> Totale pezzi per scatola di montaggio Canna Affusto tipo “A” Cuneo di alzo Base del cuneo Aggiustare di montaggio in modo che la canna rimanga orizzontale e di centro del sabordo Tutte le quote non indicate sono identiche a quelle dell’affusto Tipo “A”	<b>12-POUNDER GUNS</b> List of total pieces need for assembly of gun carriages Gun barrel Gun carriage type “A” Wedge to lift cannon Base of wedge Fix assembly in such a manner that the cannon remains horizontal and in the centre of the leading edge All dimensions not indicated are identical to those of carriage Type “A”
<b>PORTA PROIETTLI</b> Pullini di plumbo	<b>CANNONBALL RACKS</b> Lead cannon balls, 1 mm. diameter
<b>SCALE</b> Ricavare in scala dai boccaporti della TAV. H da determinare a montaggio	<b>STAIRS</b> Derive in scale from the hatchways on Plan 6 Determine height on assembly & fitting
<b>ARTIGLIERIA DA 4 LIBRE</b>	<b>4-POUNDER GUNS</b>
<b>ANCORA</b> Ancora di speranza/ posta	<b>ANCHORS</b> Refer to Euromodel ‘nautical terms’

<b>Tavola 7</b> <b>BOMPRESSO ALBERI E PENNONI</b> <b>ETC</b>	<b>Plan Sheet 7</b> <b>BOWSPRIT, MASTS, YARDS, ETC.</b>
<p><b>A. BOMPRESSO</b> Lamierino mm. 0.1 *Definire a montaggio Tratto d sezione quadra Aggiustare al montaggio. L’asse del bompRESSO deve essere und inclinazione di 29° rispetto id linea di galleggiamento</p> <p>Mastra</p>	<p><b>A. BOWSPRIT</b> Metal band, 0.1 mm. thickness *Refer when installing Square out end Shape this end to match when assembling. The centerline of the bowsprit must be placed on an angle of 29o referring to the waterline</p> <p>Bowsprit collar/ coaming</p>
<p><b>A1. ASTA DI FIOCCO</b> Tratto d sezione ottagonale</p>	<p><b>A1. JIB BOOM</b> End is octagonal</p>
<p><b>A2. ASTA DI BANDIERA DI BOMPRESSO</b></p>	<p><b>A2. BOWSPRIT FLAG POLE</b></p>
<p><b>A3. TESTA DI MORO DI BOMPRESSO</b></p>	<p><b>A3. BOWSPRIT CAP</b></p>
<p><b>A4. PENNACCINO</b></p>	<p><b>A4. JUMPER STRUT</b></p>
<p><b>A5. PENNONE DI CIVADA</b> Marciapiede del p. di civada mm. 0.5 Particolare tipico del marciapiede del ... etc</p>	<p><b>A5. SPRITSAIL YARD</b> Footrope of spritsail yard, 0.5 mm. diameter Detail typical of footrope for a yard (not to scale)</p>
<p><b>B. ALBERO DI TRINCHETTO</b> Lamierino mm. 0.1 Determinare d montaggio strollo di maestra Tratto d sez. Quadra Determinare d montaggio controstrollo di maestra Altezza dal ponte di coperta</p>	<p><b>B. FOREMAST</b> Metal band, 0.1 mm. thickness Position of main stay to be determined on assembly Squared-off section Position of main stay to be determined on assembly Height above main deck</p>
<p><b>B1. COFFA DI TRINCHETTO</b> Particolari da realizzarsi a cura del modellista Legno compensato sp. 1mm.</p>	<p><b>B1. FOREMAST TOP</b> Detail to be created by modeler Plywood, thickness 1mm.</p>
<p><b>C. ALBERO MAESTRA</b> Cuoio sp. 0.1mm Squadra a disegno/ opposta N.B.L’albero di maestro deve risultare inclinor di 2° verso la poppa rispetto la perpendicolare alla linea di galleggiamento... etc.</p> <p>Altezza dal ponte di coperta</p>	<p><b>C. MAIN MAST</b> Leather, 0.1mm. thickness Each of two pieces is squared on opposite sides N.B. Main mast must have a 2° incline towards stern referring to the perpendicular at the waterline. The mast top, the mast caps and topmast crosstree must be parallel to the waterline. Height above main deck</p>
<p><b>C1. COFFA DI MAESTRA</b> La coffe si realizza ritagliando la tavoletta di compensato da mm. 1 e rivestendo la stessa con listelli di noce da mm. 0.5x3</p>	<p><b>C1. MAIN MAST TOP</b> The top created by cutting out 1mm. thickness plywood by reference to plan and covering with walnut strips 0.5 x 3 mm.</p>
<p><b>C1.A. FANALE DI COFFA</b></p>	<p><b>C1.A. TOP NAVIGATIONAL LIGHT</b></p>

<b>Tavola 8</b>	<b>Plan Sheet 8</b>
<b>MANOVRE CORRENTI DEI PENNONI</b>	<b>RUNNING RIGGING OF YARDS</b>
<b>PARTICOLARE DEI PARANCHI DI DRIZZA DEI PENNONI DI TRINCHETTO E DI MAESTRA (fuori scala)</b> Barre costiere della coffa (per maggior chiarezza la coffa non e stato rappresentata)	<b>DETAILS OF THE HALYARD TACKLE FOR THE MAIN &amp; FOREMAST YARD ARMS (not to scale)</b> Mast top trestle tree (for better clarity, top is not fully drawn)
<b>PARTICOLARE DELLA DRIZZA DEI PENNONI DI PARROCCHETTO E DI GABBIA (fuori scala)</b>	<b>HALYARD DETAILS OF THE YARDS FOR THE FORE &amp; MAIN LOWER TOPSAIL YARDS (not to scale)</b>
<b>PARTICOLARE DELLA TROZZA DEI PENNONI DI PARROCCHETTO E DI GABBIA (fuori scala)</b> TOTALE n° 27 PEZZI No 7 per trozza asto di mezzane No 10 per pennone di parracchetto No 10 per pennone di gabbia Steretto in legno 1; forate; oppure perline in vetro dd bi jiotterid dipinte color legno	<b>PARREL DETAILS OF THE YARDS FOR THE FORE &amp; MAIN LOWER TOPSAIL YARDS (not to scale)</b> Total of 27 pieces 7 pieces for mizzen mast gaff 10 pieces for the fore topsail yard parrel 10 pieces for the main topsail yard Wood balls 1 mm in diameter drilled with hole or glass beads painted like wood
<b>PARTICOLARE DELLA TROZZA DEI PENNONI DI TRINCHETTO, MAESTRA E MEZZANA (fuori scala)</b>  Bozzelli fissati sotto le barre traverse delle coffe Salsiccio di cavo intrecciato (0.4) e rivestito in cuoio sp. 0.1 Cuoio non e compresso nella scalola di montaggio	<b>PARREL DETAILS OF THE YARDS FOR THE FORE, MAIN &amp; MIZZEN YARDS (not to scale)</b>  Blocks fixed underneath crosstree of top A ‘dolphin’ made of interwoven rope and covered in leather 0.1mm thickness Leather not supplied in kit
<b>PARTICOLARE DELLA TROZZA DELL’ASTA DI MEZZANA (fuori scala)</b>	<b>PARREL DETAILS FOR THE MIZZEN YARD (not to scale)</b>
<b>DETTAGLIO ‘A’ (fuori scala)</b> Anello in filo acc. ... etc  Filo acc. 0.5mm	<b>DETAIL OF RING ‘A’</b> Steel wire ring, diam. 1mm. (exterior diam. 8mm) Steel wire ring, 0.5mm. diam.

<b>Tavola 9 VELE DI TAGLIO</b>	<b>Plan Sheet 9 STAY SAILS</b>
<p>La corda della vela di strallo di controvelaccio (6) deve passare in un bozzello di tipo "L" fissato all'interno dell'ultima sartia di dritta dell'albero di parrocchetto e scendere lungo l'albero ed essere legato ad una galloccia fissata all'interno dell'ultima sartia di trinchetto all'altezza della terza grisella ... etc.</p> <p>Le due corde della vela di strallo di velaccio(5) devono passare in due bozzelli di tipo "L" e fissati uno a destra e l'altro a sinistra nell'interno dell'ultima sartia verso poppa dell'albero di parrocchetto, scendere lungo l'albero ed essere legata a due galloccie fissate all'interno della penultima sartia di maestra (verso poppa) all'altezza della terza grisella.</p> <p>Le due corde della vela di strallo di contromezzana devono passare (una a destra e una a sinistra) in una bigotta tipo "E" fissata all'interno della prima corda of main mast verso prora ed essere legate a una galloccia fissata pi in basso all'interno della stessa corda.</p> <p>Per i vari simboli rappresentati sulla presente vedere la legenda di Tav</p>	<p>The lead of the main royal staysail No. 6 passes through a block of type "L" which is tied on the inside of the right shroud of the fore topsail mast. This lead goes down along the mast to a cleat on the inside of the last shroud of the foremast at the height of the third ratline beginning from the bottom</p> <p>The two ropes of topgallant staysail No. 5 passes through two blocks type "L" which are tied one on the right and one on the left on the inside of the last shroud (towards stern) of the fore topsail mast. The leads run down alongside the mast are tied to two cleats installed on the inside of the next to last shroud of the main mast (towards stern) at the height of the third ratline.</p> <p>Two two leads of the mizzen topgallant staysail must pass through (one on the right and one on the left) of the deadeyes type "E" installed on the inside of the first of the main shroud towards the bow of rope and will be tied at a cleat installed on the same shroud but lower.</p> <p>For the list of symbols used on this plan, refer to Plan Sheet 1</p>
<p><b>DETTAGLIO DELLE SCOTTE DEI PIOCCHI E VELE DI STRALLO (fuori scala)</b> Lato di barboardo Lato di tribordo</p>	<p><b>DETAILS OF JIB SHEETS &amp; STAY SAILS (Not to scale)</b> Port side Starboard side</p>
<p><b>DETTAGLIO DELLE ESTRIMATA DEI FIOCCHI E DELLE VELE DI STRALLO ...etc</b> Anelli esterno 4 in filo di acc 0.4</p>	<p><b>DETAILS OF RIGGING FOR JIB AND STAY SAILS (not to scale)</b> 4 mm. ring seized with 0.4 mm. thread</p>
<p>La '6' passa nella cavatoia superiore a destra dell'albero. La '7' passa dallo stesso lato nella cavatoia inferiore. La '8' pass nelle due ... etc.</p> <p>La '1' pass nella cavatoia con puleggia superiore sul lato sinistro dell'albero. La '3' passa dallo stesso lato nella cavatoia inferiore. La '2' passa nelle due cavatoie a destra dell'albero.</p>	<p>Rope 6 passes through upper hole on right side of mast. Rope 7 is inserted on same side of mast through lower hole. Ropes 8 pass through hole on the left side of mast.</p> <p>Rope 1 passes through upper hole (over pulley) on right side of mast. Rope 3 is inserted on same side of mast through lower hole. Rope 2 passes through the hole on the left side of the mast.</p>

<p><b>Tavola 10 &amp; 11 ALBERI, PENNONI E PARTICOLARI</b></p> <p><b>Tavola 12 – VELE ALBERO DI MAESTRA E PARTICOLARI</b></p> <p><b>Tavola 13 – VELE DI TRINCHETTO E MEZZANA</b></p>	<p><b>Plan Sheets 10 &amp; 11 MAST &amp; YARD DETAILS</b></p> <p><b>Plan Sheet 12 – DETAILS OF MAIN MAST SAILS</b></p> <p><b>Plan Sheet 13 – FORE &amp; MIZZEN SAILS</b></p>
--	--

<b>Tavola 14</b> <b>PIANTA MANOVRE; BOZZELLI E BIGOTTE</b>	<b>Plan Sheet 14</b> <b>LOCATION OF BELAYING PIN RACKS &amp; CANNON BALL RACKS; DEADEYES &amp; BLOCK</b>
<b>BIGOTTE A CANALI (Scala 2:1)</b>	<b>GROOVED DEADEYES (Scale 2:1)</b>
<b>DETTAGLIO DELLO STROPPO IN ACC. DEI BOZZELLI</b>	<b>DETAIL OF METAL STRAPPING AROUND BLOCKS</b>
<b>BOZZELLI (Scala 2:1)</b> <b>Errata Corrige: I bozzelli tipo Y/H e 2Y/2H sono di eguali dimensioni e non Y/L e 2Y/2L.</b> <b>I bozzelli tipo M/L sono di eguale misura</b> Incollare N° 4 bozzellie da mm. 4 Nella scatola hanno ugual misura i bozzelli	<b>BLOCKS (Scale 2:1)</b> <b>Error Correction: The blocks type Y&amp;H, 2Y&amp;2H, are of the same size and not type Y&amp;L and 2Y&amp;2L.</b> <b>The blocks type M&amp;L are of the same size.</b> Need to glue 4 blocks together, each of 4mm. Blocks Y & L/ 2Y & 2L are of the same size
<b>LEGENDA</b> Indica il n° progressivo della caviglia o galoccia a cui deve essere data rotla la manovra volante Indica che alla manovra deve essere data rotla sulla bitta contrassegnata dal no nel cerchio Indica che manovra ra legata all’anello dei corrispondenite bozzello fisso.	<b>LEGEND</b> Shows the number of the belaying pin or cleat where the running rigging must be tied. Shows where the running rigging must be tied to the bitt marked by the number in the circle Shows where the running rigging is tied to the strap of the corresponding block.
<b>SIGLATURA DEI BOZZELLI</b> La sigla tra virgolette identifica il tip di bozzello. Il no dopo la sigla e il progressivo relativo a ciascun tipo bozzello.  Esempio: “2L” ... bozzello a 2 passaggi del tipo “L” 4 ... block N.4 of shown code	<b>DETAIL OF THE BLOCK CODES</b> Code markings of the blocks – the letters in between “ “ identify the types of blocks – the number after the code in between “ “ indicates the progressive type of block. Block with 2 holes, type “L” Block No. 4 of shown code
<b>DA REALIZZARE A CURA DEL MODELLISTA</b> Le sigle tra parentesi indicano il corrispondente bozzelle sol lato opposto a cui e mostrato ... etc Indica il punto di passaggio di una manovra volante (bozzello, passaggio a murata etc.) prima ... etc. Indica il no. Progressivo del punto fisso...etc	<b>TO BE CREATED BY THE MODELLER</b> The code in brackets indicate the corresponding block on the opposite side of view shown in the plan. Indicates the passage of running rigging (block or pass-through bulwarks, etc.) before being fastened. Indicates the sequential order of fixing of the rigging.
	Refer to Euromodel web site ... ‘Nautical Terms’

<b>Tavola 15</b> <b>MANOVRE</b>	<b>Plan Sheet 15</b> <b>FIXED RIGGING</b>
<b>PARTICOLARE DELLE CROCCETTE (fuori scala)</b>	<b>CROSTREE DETAIL</b>
<b>PARTICOLARE DELLO STRALLO ... etc</b> Cuoio sp. 0.1mm Non compressa nel scatola di montaggio	<b>DETAIL OF THE MIZZEN STAYS</b> Leather, 0.1mm. thickness Not included in this kit
<b>PARTICOLARE 1</b>	<b>DETAIL 1</b>
<b>PARTICOLARE DELLE RIGGIE DELLE BIGOTTE DELLE COFFE E DELL ... etc</b>	<b>DETAILS OF THE DEADEYE STRAPS FOR THE CROSTREES AND TOPS (not to scale)</b>
<b>PARTICOLARE DELLE LANDE DELLE BIGOTTE DEI PARASARTIE (fuori scala)</b>	<b>DETAILS OF THE STRAPPING FOR THE CHANNEL DEADEYES (not to scale)</b>
<b>PARTICOLARE 2 (fuori scala)</b> Cavo 2 fasciato con cavo 0.1	<b>DETAIL 2 (not to scale)</b> 2 mm. thread covered with 0.1 mm. thread
<b>PARTICOLARE DELLE GRISELLE(fuori ... etc)</b>	<b>DETAIL OF THE RATLINES (not to scale)</b>
<b>PARTICOLARE DEGLI INCAPPELLAGGI DEGLI</b>	<b>DETAIL OF THE TOP OF THE STAYS (not to scale)</b>

<b>STRALLI (fuori scala)</b>	
<b>PARTICOLARE DEGLI INCAPPELLAGGI DELLE SARTIE (fuori scala)</b>	<b>DETAIL OF THE TOP OF THE SHROUDS (not to scale)</b>

<b>Tavola 16 MANOVRE</b>	<b>Plan Sheet 16 DETAILS OF FIXED RIGGING</b> Refer to Euromodel web site ... ‘Nautical Terms’
<b>PARTICOLARE 1 (scala 2:1)</b>	<b>DETAIL1 (scale 2:1)</b>
<b>PARTICOLARE DELL’ATTREZZATURA DEL BOMPRESSA E DELL’ASTA DI FIOCCO ...etc</b> Travergini in legno mm. 0.5x1.5x14.5 Cuoio sp. 0.1mm	<b>DETAIL OF THE BOWSPRIT &amp; JIB BOOM RIGGING (2:1 scale)</b> Wooden strips 0.5x1.5x14.5 mm. Leather, 0.1mm. thickness
<b>PARTICOLARE IN PIANTA DELL’ATTREZZATURA DEL ... etc</b> N.B. Escluso gli arridatoi delle bigotte e i tiranti die bozzelli che sono color corda naturale, tutte le altre manovre de vono essere tinte color ... etc.	<b>HORIZONTAL VIEW OF THE BOWSPRIT &amp; JIB BOOM RIGGING</b> N.B. Except for the deadeyes & block rigging which is of natural colour rope colour, all the other rigging must be painted dark brown to simulate the tarring of them.
<b>PARTICOLARE DELLE COFFE DI TRINCHETTO E MAESTRA (fuori scala)</b> N.B. Nella vista laterale delle coffe sono state omesse le bigotte e le sartie per maggior chiarezza. Le parti indicate con linea e punto sono relative al solo albero di maestra. Il diametro delle manovre e il tipo di bozzello al di sopra della linea sono relativi all’albero do maestra; quelli al di sotto della linea all’al ... etc Rete di filo 0.1 maglia Romboidale 2x1mm; colore: marrone Non compressa nella ... etc	<b>DETAILS OF THE FOREMAST &amp; MAINMAST TOPS (not to scale)</b> N.B. On the side view of the tops, the deadeyes and the shrouds have been omitted for better clarity. Parts indicated with dot and dash lines refer only to the mainmast. The diameters of the rigging above the line refer to the mainmast and those under the line refer to the foremast. Thread netting 0.1mm. diameter Diamond-shaped netting 2x1mm; brown colour Not supplied in kit
<b>CAVALLETIO DI SOSTEGNO (da eseguirsi in legno pregiato)</b>	<b>DISPLAY STAND (made from good quality wood)</b>
<b>NOTE</b> Tutte le superfici delle coffe, le barre costiere, le barre traverse, le teste di moro, le crocette, i tratti di albero trale coffe e la teste di moro e tra le crocette e la teste di moro, sono di color nero semilucido. Per la legenda dei simboli usati sulla presente, perle bigotte i bozzelli ed i particolari indicati ner due cerchi concentrici vedere la Tav 14	<b>NOTE</b> The surfaces of the tops with their crosstrees and trestle trees plus the caps, the crosstrees and pieces of mast between the caps and the tops and between the crosstrees and the caps are semi-gloss black. For the list of symbols used in this table for the deadeyes, the blocks and the details indicated in the double circles, see Plan 14

<b>Tavola 17 PIANO DI COSTRUZIONE E PARTICOLARI</b>	<b>Plan Sheet 17 BUILDING PLAN</b>
<b>PIANO LONGITUDIANLE</b>	<b>LONGITUDINAL DRAWING</b>
<b>PIANO ORIZZONTALE (linee d’acqua)</b>	<b>HORIZONTAL DRAWING (water lines)</b>
<b>PIANO TRASVERSALE (ORDINATE)</b>	<b>OVERALL DRAWING (FRAME CAMBER)</b>
Curvatura del bozone Linea retta del baglio	Deck curvature Imaginary line used to detect curvature of deck

<p><b>CHIGLIA – Materiale: legno pregiato</b>                  Contrallare la lunghezza sullo scafo finito e ... etc.                  Lasciare mater in piv.                  Eseguire a montaggio P.27</p>	<p><b>KEEL DETAIL : Special wood</b>                  Check length of the hull with part 27                  Leave extra material                  Make this cut when matching with part 27</p>
<p><b>DRITTO DEL TIMONE</b>                  Materiale: legno pregiato                  Profilo corrispondente a quello della chiglia                  Tagliare dopo il montaggio</p>	<p><b>RUDDER POST DETAIL</b>                  Material: special wood                  The shape must be the same as the keel                  Cut out after installing</p>
<p><b>TIMONE – Materiale: legno pregiato</b></p>	<p><b>RUDDER DETAIL – Material : special wood</b>                  This cut follows the line of the keel                  Hinges detail (scale 2:1) – male hinges                  Pin 0.5 mm diameter (make from a pin)                  Metal strip of burnished brass 0.1 mm. thickness, inside diameter 0.75 mm.                  Detail of female hinges (not to scale)</p>
<p><b>BARRA DEL TIMONE – Materiale: legno pregiato</b></p>	<p><b>RUDDER BAR DETAIL – Material: special wood</b>                  This angle is determined when installing so that the bar is in a horizontal position. Install the pin so that the bar is fastened to the rudder.</p>

## Chapter 3: THE KIT

### Drawings

A point I found useful was for many – but not all – plan sheets to be carefully cut into small sections and placed into plastic sleeves in a folder. This way I could arrange the drawings in semblance of order of construction. Another very useful step was to print off the Italian-English translations, cut out the English translations and stick them over the appropriate Italian words (Fig. 6). The photo does not show LeRenommee detail but gives the idea !

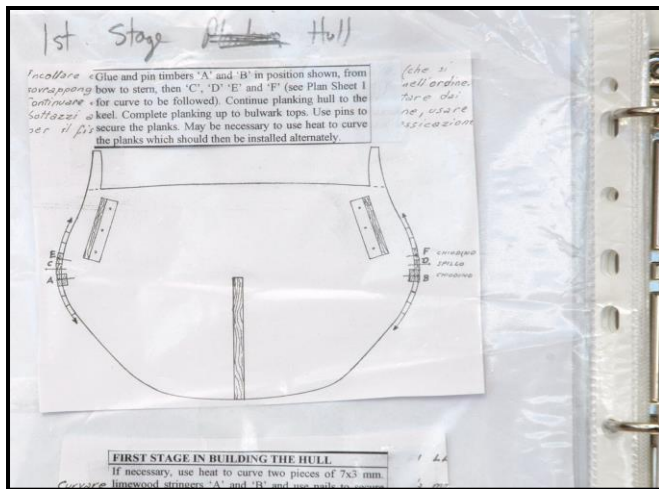

Figure 5: Organisation of Plan Sheet Material

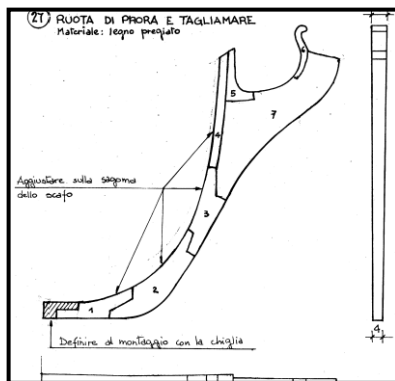

Figure 6: Stem Post Detail Which You Might Use

The diagrams are beautifully drawn and allow a scratch-built kit to be readily developed. The difficulty is to separate the essential detail necessary to build the kit from the other more seriously accurate detail. The drawing opposite depicts a composite collection of timbers forming the stem (bow) post. The kit supplies one laser-cut stem post without any detail whatsoever. So you can decide to produce all the component parts (a big task) or simply go with the blank piece as it is supplied. What you could do is to carve all the joint lines onto the surface to simulate the individual pieces.

### Metal decorations

decorations are contained in plastic packets. They have very remove. On the reverse side of specific number that identifies some excellent side and stern instructional manual that allows identify the castings with little time to go through every packet, What I then did was to place an number inside each packet and future use.

Much patience is required to identify these pieces and I would caution against direct contact with the skin – use gloves when cleaning & painting the pieces. Certainly any filing should be carried out in a separate area that can be easily cleaned up. Obviously any painting and gilding will need to be done before assembly onto the ship. More on their usage later.



Figure 7: Identification of Metal Parts

All cast metal small but unmarked few blemishes to the casting there is a that piece. There are views on pages in the the kit builder to problem. Now is the identify the pieces. identifying name or re-staple them ready for

### Scrap Material

The laser-cut material in this kit is surrounded by pieces of wood which may appear to be superfluous – do not discard this ‘waste’ as there will be a number of places in the ship build where it becomes useful.

## Component list

### Wood – Laser-cut

<b>Hull: Keel (1)</b> – Chiglia	<b>Transverse Frames (14)</b> - Ordinate
<b>Decks: Gun Deck (1)</b> - Ponte di batteria	<b>Main Deck (1)</b> - Ponte di coperta
<b>Quarter Deck (1)</b> – Ponte di cassero	
<b>Stern: Stern Balcony Supports (4)</b> - Supporti di balconata No. 16	
<b>Stern Balcony/ Transom (1)</b> - Particolare N°17	
<b>Rudder (1)</b> – Timone	
<b>Posts: Stem (Bow) Post (1)</b> - Ruota di prua	<b>Stern Post (1)</b> – Ruota di poppa
<b>Support Base (1)</b> - Invasatura anteriore + posteriore	

### Limewood – listello tiglio

35 x 35 x 100 mm.	<b>Filler Blocks for Bow</b> - Blocchetto di riempimento di prua -
25 x 28 x 120 mm.	<b>Blocks for Quarter Deck Entrance</b> - Blocchetto per porte cassero
1.5 x 6 x 650 mm. (60)	<b>First Planking</b> - 1° Fasciame

### Plywood- compensata

1 x 60 x 200 mm.	<b>Mast Tops</b> - Coffe
------------------	--------------------------

### Ramin - ramino

3 x 20 x 200 mm. (1)	<b>Mast Cheek</b> - Maschette
2 x 7 x 300 mm. (1)	<b>Main Mast Extended Cheeks</b> - Rinforzi albero di maestra
2 x 6 x 250 mm. (1)	<b>Fore Mast Extended Cheeks</b> - Rinforzi albero di trinchetto

### Walnut – listello noce

1.0 x 6 x 650 mm. (60)	<b>Second Planking</b> - 2° Fasciame
0.5 x 4 x 600 mm. (45)	<b>Deck Planking</b> - Rivestimento ponti
10 x 10 x 200 mm. (1)	<b>Cradle Support Cross Pieces</b> - Traversa invasatura
6 x 7 x 590 mm. (1)	<b>False Keel, Rudder Post</b> - Sottochiglia , Dritto del timone
1.5 x 3 x 500 mm. (1)	<b>Poop Rails, Bulwark</b> - Balaustra
1x 1.5 x 500 mm. (1)	<b>Poop Rails, Bulwark (&amp; Top Ribs)</b> - Balaustra
4 x 4 x 300 mm. (1)	<b>Rudder Bar, Stern Support:</b> Barra timone, Sostegno specchio di poppa
0.5 x 3 x 500 mm. (6)	<b>Mast tops</b> - Coffe
2 x 2 x 390 mm. (1)	<b>Crosstrees, Mizzen Lower Mast</b> - Barre traverse albero di mezzana
3.5 x 5 x 110 mm. (1)	<b>Trestletrees, Main Mast</b> - Barre costiere albero di maestra
3 x 3 x 300 mm. (3)	<b>Bulwarks &amp; Crosstrees of Main Mast &amp; Foremast</b> - Balaustra , Barre traverse albero di maestra e albero di trinchetto
3 x 4.5 x 100 mm. (1)	<b>Trestletrees, Foremast</b> - Barre costiere albero di trinchetto
2 x 3.5 x 70 mm. (1)	<b>Trestletrees, Mizzen Mast</b> - Barre costiere albero di mezzana
2 x 11 x 500 mm. (1)	<b>Channel</b> – Parasartie
1 x 6 x 500 mm. (1)	<b>Pin Rails</b> - Cavigliera
5 x 5 x 300 mm. (2)	<b>Pin Rails &amp; Catheads</b> - Paziienza e Gru di capone
1 x 2 x 200 mm. (1)	<b>Ratlines</b> - Griselle
2 x 2 x 600 mm. (2)	<b>Cap Rail</b> - Capodibanda
2 x 12 x 630 mm. (2)	<b>Wale</b> - Incintoni
1.5 x 2 x 600 mm. (4)	<b>Quarter Deck reinforcement of bulwarks</b> - Rinforzi di murata
1.5 x 5 x 600 mm. (2)	<b>Cap rail base</b> - Base capodibanda
1.5 x 11 x 400 mm. (1)	<b>Gun Port Hatch</b> - Portelli cannoni
1 x 8 x 400 mm. (1)	<b>Gun Port Lining</b> - Battuta portelli cannoni

## Accessories

**Anchor 50mm with stock & ring (2)** - Ancora da mm. 50 con ceppo ed anello(Art.11/131)

**Anchor 40mm with stock & ring (2)** - Ancora da mm. 40 con ceppo ed anello(Art.11/009)

**Barrel (1)** – Botte (Art.22/112)

**Belaying Pins, 8mm. (156)** - Caviglia da mm. 8 (Art.22/144)

**Bell (1)** – Campana (Art.11/107)

**Binnacle (1)** - Chiesuola campana (Art.11/363)

## Blocks

N.B. The plan sheet shows a larger variation of block sizes than that provided in the kit. This kit has amalgamated a number of blocks with similar sizes together – e.g. G, Y and H all use the same sized block.

**G/Y\*/H\*:** **3mm., 1 hole(178)** - Bozzelli da mm. 3 a 1 foro (Art.22/026)

**34/2L/2Y\*:** **4mm., 2 hole(123)** - Bozzelli da mm. 4 a 2 foro (Art.22/031)

**M:** **5mm., 1 hole (40)** - Bozzelli da mm. 5 a 1 foro (Art.22/028)

**2M:** **5mm., 2 hole (2)** - Bozzelli da mm. 5 a 2 fori (Art.22/032)

**3M/ 3L\*:** **5mm., 3 hole (37)** -Bozzelli da mm. 5 a 3 fori (Art.22/113)

**N:** **7mm., 1 hole (9)** - Bozzelli da mm. 7 a 1 fori (Art.22/030)

**2N:** **7mm., 2 hole (8)** - Bozzelli da mm. 7 a 2 fori (Art.22/034)

**F\*:** **Violin, 6 mm. (4)** - Bozzelli a violino da mm. 8 (Art.22/083)

**34\*:** **Heart, 7 mm. (6)** - Bozzelli a cuore da mm. 7 (Art.22/157)

**35\*/36:Heart, 10 mm. (3)** - Bozzelli a cuore da mm. 10 (Art.22/085)

\* Not available commercially

37\* + 38\* not enclosed in kit

**Brass Rod, 1mm., support for rails(34) & tops main mast & foremast(8)** - Tondino ottone mm. 1

**Buoy (4)** - Gavittello (Art.22/145)

**Capstans:**

**Basic : 11x16 mm. (1)** - (Art.22/135); **15x20 mm. (1)** – Argano (Art.22/134) [Errore. L'origine riferimento non è stata trovata.](#)

**Advanced : 15x20 mm. (1)** - (Art.22/134); **20x25 mm. (1)** – Argano (Art.22/133) [Errore. L'origine riferimento non è stata trovata.](#)

i.e. 3 capstans included, using two depending on skill level

**Chain Plates:**

**3mm.,(8)**- Landra da mm. 3 (Art.11/358)

**5mm.,(50)**- Landra da mm. 5 (Art.11/313)

**Cleats (67)** - Galloccia (Art.11/048)

**Deadeyes:**

**E/33: 3mm.(1-hole) (3)** - Bigotte da mm. 3 (Art.22/136)

**C: 3mm.(3-hole) (50)** - Bigotte da mm. 3 (Art.22/018)

**D: 5mm.(1-hole) (2)** - Bigotte da mm. 5 (Art.22/137)

**X: 5mm.(2-hole) (2)** - Bigotte da mm. 5 (Art.22/138)

**B: 5mm.(3-hole)(128)** - Bigotte da mm. 5 (Art.22/020)

**Eye Pins (62)** - Anellino con gambo (Art.11/022)

As is common practice with kits from other manufacturers, Euromodel does not provide eye pins provided for gun carriage rigging. Thus the majority of models do not show this finer point of rigging – however, you may wish to do so by providing extra eye pins. The eye pins that are provided are as follows ...

- bowsprit cap – 4
- bowsprit – 2
- catheads - 6
- foremast caps – 4
- main mast caps – 8
- mizzen cap – 2
- main deck rigging points – 22
- trestletree rigging points – 14 (only needed if adding sails; if insufficient number of eye pins in kit, then holes can be drilled through the trestletrees)

**Euromodel has only recently changed this number so you may have to make do with a lesser number (refer to previous comment above)**

**Flag set (1)** - Serie completa bandiere (Art.13/035)

### **Armament**

**Full Cannons** - Cannoni:

**30mm. (12)** (Art.11/119)

**40mm. (30)** (Art.11/120)

**Gun Carriages**-Affusti per cannoni **19mm. (12)** (Art.22/001); **27mm. (30)** (Art.22/125)

**Gun Door Hinges (30)** - Cerniere portelli cannoni (Art. 11/129)

**Wheels** - Ruote per cannoni **diam. 4mm.(24)** (Art.22/148); **diam. 5mm. (84)** (Art.22/149);  
**diam. 6mm.(60)** (Art. 22/150)

**Axles (carriage wheels)**

**wooden rod 2 x 200mm (3)**- Tondini di kotò diam.mm. 2 per assali affusti

**Axles (cannons)**

**brass rod 1.5 x 130mm. (3)** -Tondino ottone da mm. 1.5 per spine cannoni

**brass rod 1 x 130mm. (6)** -Tondino ottone da mm. 1 per spine cannoni

**Grating Strips 1.0 x 1.0 x 33mm (290)** - Elementi per paiolato da mm. 33 (Art.22/056)

**Lantern, Topsail (1)**- Lanterna di gabbia (Art.55/005)

**Mast Caps** – Testa di moro : [following dimensions are those that I determined from the pieces supplied in kit]

**C2: Main Mast** (di maestra) (1) (Art.22/139): [13.17 x 26.16 mm]

**C5: Main Topmast** (di gabbia) (1) (Art. 22/22/140) : [9 x 18.9 mm.]

**D2: Mizzen Mast** (di gabbia e mezzana) (1) (Art.22/140) : [9 x 18.9 mm.]

**B2: Foremast** (di trinchetto) (1) (Art.22/141): [10.2 x 23.0]

**B5: Fore Topmast** (di parrochetto) (1) (Art.22/142): [9 x 18.9 mm.]

**A3: Bowsprit** (di bompresso) (1) (Art.22/143) : [ 9.2 x 19.4 mm.] ... supplied with both ends bevelled

**Metal Decorations Set** - Serie completa decorazioni fuse (Art.11/357)

**Plaque (1)** - Targa invaso (Art.12/008)

### **Rigging Yarn**

0.25 mm. (Art. 77/025) 0.80 mm. (Art. 77/080) /

0.40 mm. (Art. 77/040) 1.00 mm. (Art. 77/100)

0.60 mm. (Art. 77/060) 1.50 mm. (Art. 77/150)

**Rings, Brass (50)** – Anellino (Art.11/019)

**Rudder Hinges (4)** - Cerniere timone complete (Art.11/122)

**Sail Cloth, 450 x 900 mm.** - Serie tela per vele mm. 450 x 900 (Art. 15/008)

**Ship’s Boats Hulls, 80mm. + 120mm. (1+1)** - Scialuppa da mm. 80 (Art.88/003) /Scialuppa da mm. 120 (Art.88/002)

**Stairs - 9 steps (3)** - Scala (Art.22/069)

**Stanchion Cleats (e.g. ‘staghorns’) (10)** - Tacchetti (Art.11/271)

**Wheel, Ship’s (1)** - Ruota timone (Art.22/099)

**Set of Plans (18 sheets)** - Serie disegni (No 18 Tavole) (Art.66/00)

**Instructions** - Istruzioni

## Chapter 4: BASIC CONCEPTS EXPLAINED

### Bulwark Height

Like so many other ships, builders comment on the need for the bulwarks to be higher above the deck than is shown in the drawings. Part of Plan Sheet ‘A’ is shown below that explains the problem and provides the correction necessary.

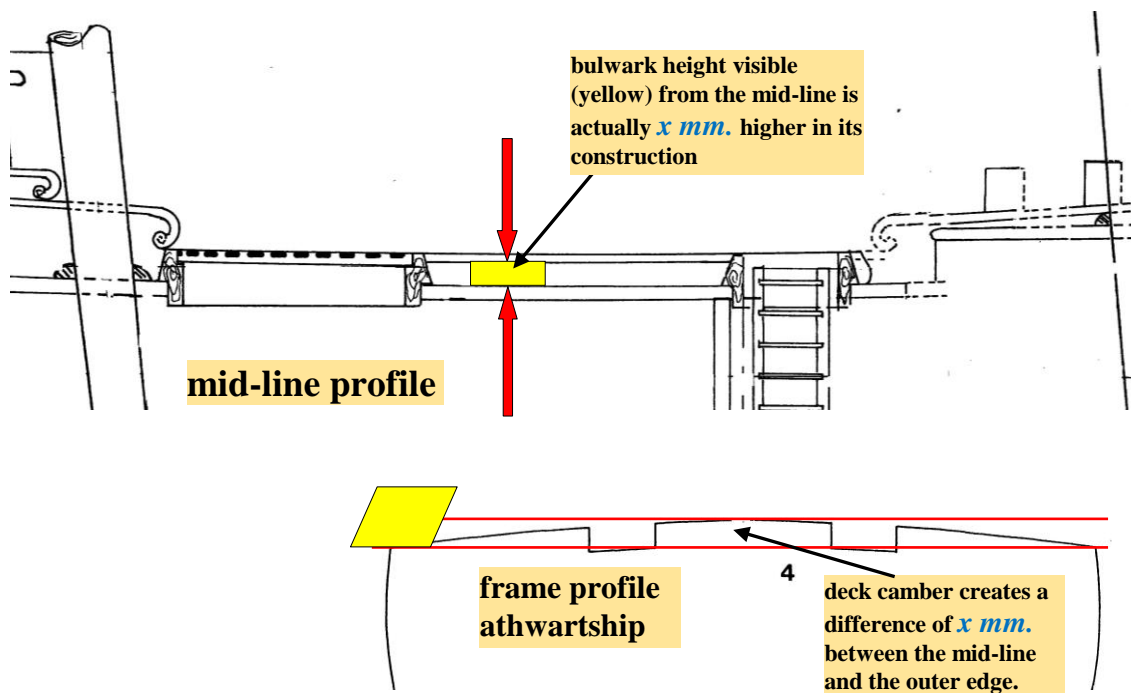

Figure 8: Bulwark Height Correction

## Chapter 5: MORE ADVANCED IDEAS

The following ideas are extensions that might be used by more experienced builders. In no way are they intended to be prescriptive for a basic build.

### Measurements

The following commentary is about taking things to an extreme ‘measure’ and only represents a whim that I decided to follow.

Maybe very few builders will ever go this extent ... but in order to interpret the plan drawings of the hull side view, it should be remembered that the drawings are a three-dimensional view shown in two dimensions. Allowances could be made for this ‘abberation’. The changes in dimension will be small and if this change is not followed, things will still fit into place. This particularly relates to ports and the wales.

**Remember though, the position of the ports was established early in the construction of the hull so what follows, for most, will be superflous !**

These techniques allows for a closer reproduction of that shown in the plan drawings.

Fig. 9 indicates how the bottom edge position of the port might be determined.

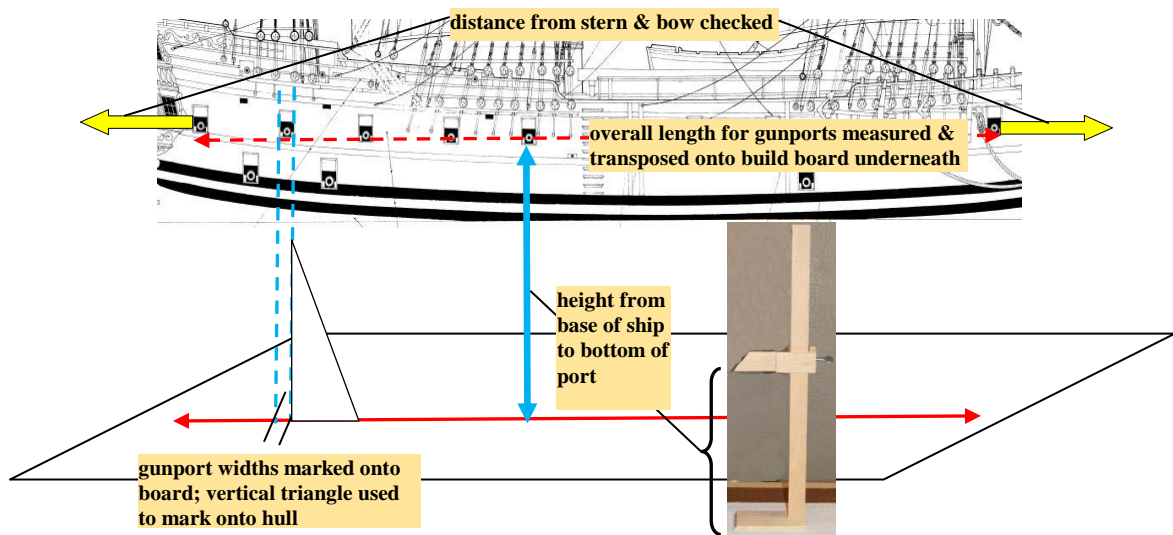

Figure 9: Establishing Gunport Positions

One aspect to double check on is the width of the ports as the bow curves – particularly the end port (chase port). On the drawings, these will appear to narrow due to their being a three-dimensional representation. In fact, all ports will have the same width.

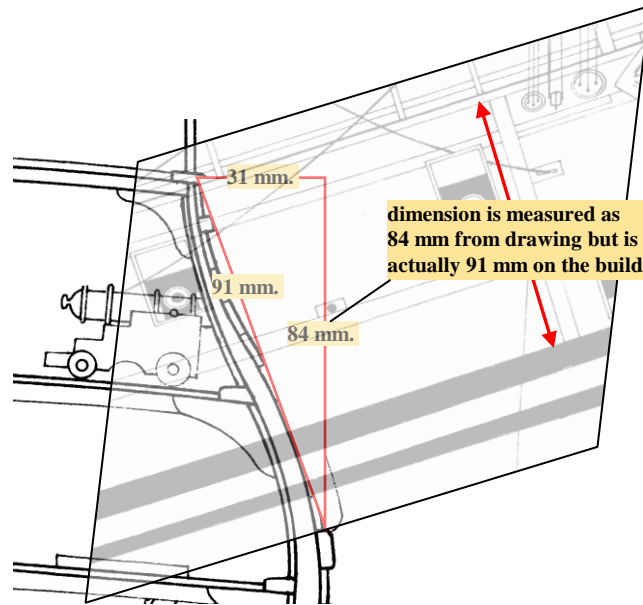

Figure 10: Making Adjustments for Three Dimensions

Fig. 10 illustrates a common problem faced by builders – the drawing illustrates what is *seen* but not what is *measured* ... it is a three-dimensional view presented as a two-dimensional view.

The figures shown in Fig. 10 were taken straight off the computer screen but the *ratio of figures will remain the same*.

84 mm. from the drawing is actually 91 mm. on the model.

For gunport and wale readings, the figures obtained would be multiplied by 91/84.

(i.e. increasing measurements by a factor of **1.083**)

e.g. **28 mm.** becomes  $28 \times 91/84 = 30 \text{ mm.}$

## Treenail (or trenail, trennel or trunnel)

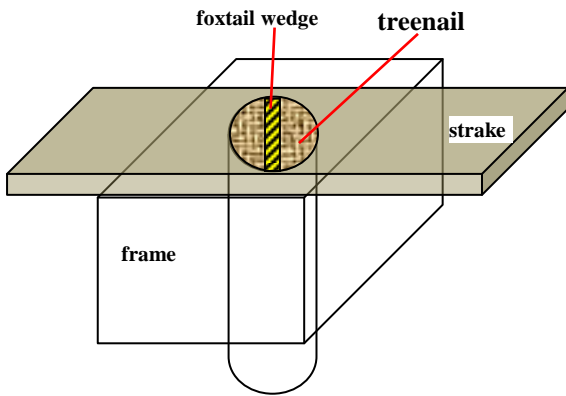

Figure 11: Diagrammatic View of Treenail

Instead of using metal fasteners to fix planks to the frames, it was common to do treenailing. This consisted of inserting wooden ‘pegs’ which were of a softer wood, into drilled holes and then expand their outer end with a wedge of much harder wood driven into them called a foxtail wedge. When the ship was immersed in water, the wooden pegs would swell and further tighten the pegs. This method worked extremely well to maintain the ship’s physical integrity.

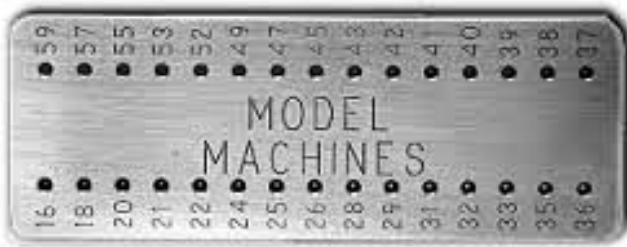

Figure 12: Byrne's Draw Plate

In ship modelling, it is common to manufacture these treenails from bamboo barbecue sticks by splitting them along their length and then passing them through a draw plate to create a specific diameter.

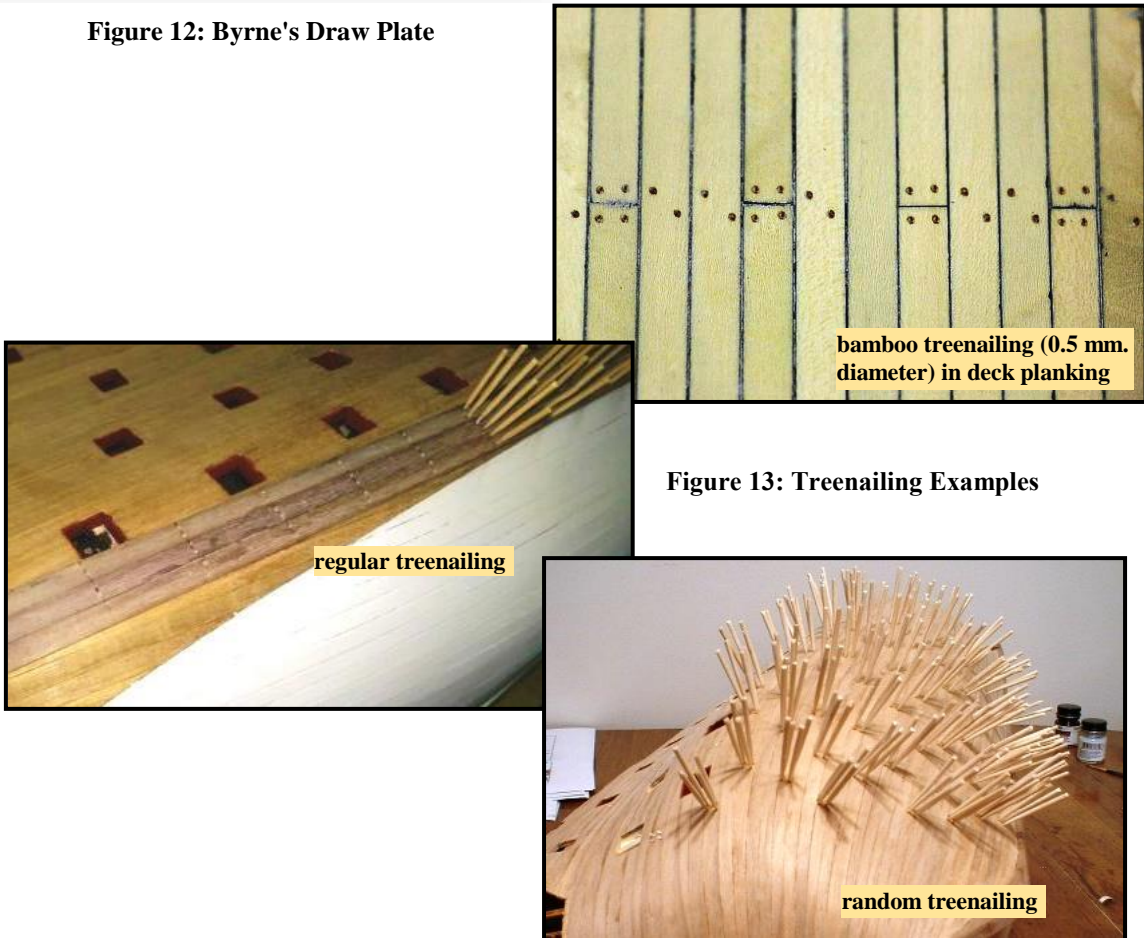

Figure 13: Treenailing Examples

## Rigging Tool

A gift came from Canada that contained this combination of a needle threader and a looper threader ... really fantastic to use. The threader is approx. 135 mm. in length which makes it a very handy length when getting amongst all the rigging.

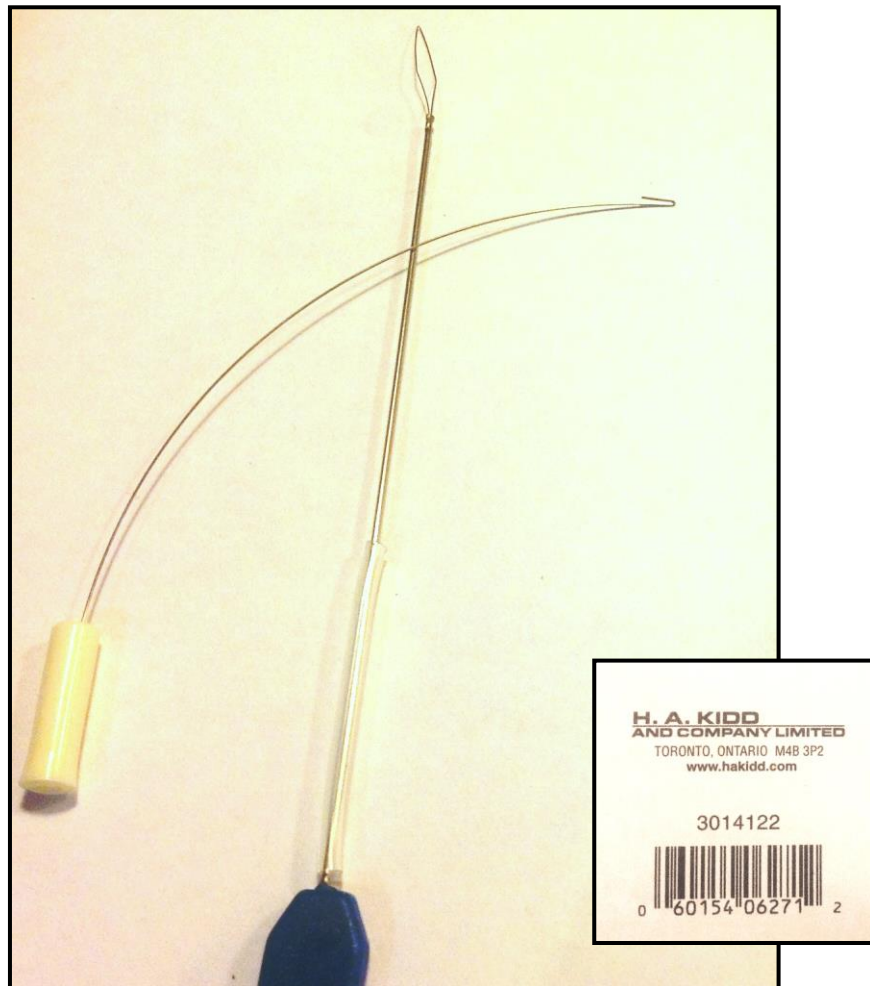

Figure 14: Two Rigging Tools

## Plank Bending

I like this machine although I do not have one (as yet). From the Micro-Mark Catalogue comes the following description ...

### ‘ Professional Quality Bending Machine Forms Smooth Curves in Wood, Plastic and Metal’

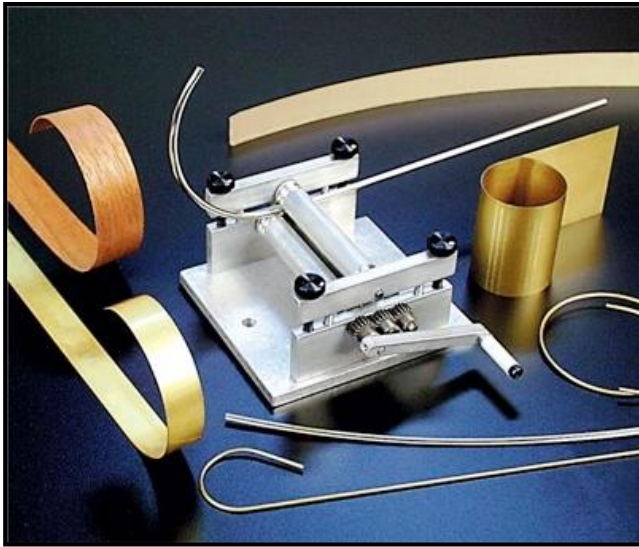

Figure 15: Micro-Mark Bending Machine

‘There's never been a better, easier-to-use tool for making perfect bends in ship model planking. *Works on wood strips up to 2-1/4 inches (approx. 57 mm.) wide and 1/8 inch (approx. 3 mm.) thick...even plywood!* ... .. Simply set the rollers for the desired radius and turn the crank to feed and form the material. ... .. Precision machined of aluminum with steel gears. Rollers are 1/2 inch (12.7 mm.) diameter by 3 (76.2 mm.) inches long.’